

On the number of cylinders touching a ball

Peter Braß*, Carola Wenk**

Institute for Computer Science, FU Berlin,
Takustrasse 9, D-14195 Berlin, Germany
brass@inf.fu-berlin.de, wenk@inf.fu-berlin.de

Abstract: In this note we prove an upper bound of seven for the maximum number of unit cylinders touching a unit ball in a packing. This improves a previous bound of eight by Heppes and Szabó. The value conjectured by Kuperberg in 1990 is six.

Mathematics Subject Classification (1991): 52C17

Key words: packing, cylinder packing, kissing number

1. Introduction

The problem to determine the maximum number of unit-radius infinite cylinders touching a unit-radius ball was first raised by W. Kuperberg [5] in 1990. This problem is analogous to the classical ‘kissing number’: the maximum number of unit balls touching a unit ball in a packing, which is six in two dimensions and twelve in three dimensions; and one would expect that the infinite cylinders essentially reduce the problem by one dimension. Packings of infinite cylinders, however, have produced some surprises already, such as the packing of positive density with no two cylinders parallel ([4], [2]), and similarly this problem turned out to be more difficult than expected. There are several known constructions of six cylinders touching a central ball: one by surrounding the ball by six parallel cylinders in a hexagonal situation (Figure 1), but it is also possible to divide them in two groups of three by a plane through the center of the ball and tangent to four of them, and rotate the groups independently (Figure 2), and there is also a configuration of six cylinders in three pairs of parallel cylinders, touching at the vertices of an octahedron (Figure 3). Heppes and Szabó [3] proved an upper bound of eight for the number of unit cylinders touching a unit ball. It is the aim of this note to reduce this bound to seven.

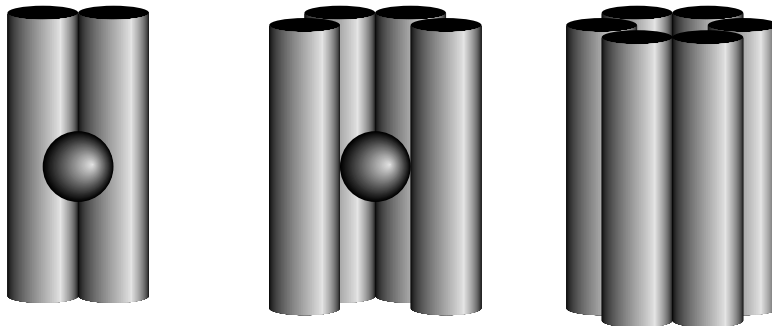

Figure 1.

* work done while supported by DFG grant BR 1465/5-1

** work done while supported by DFG grant AL 253/4-2

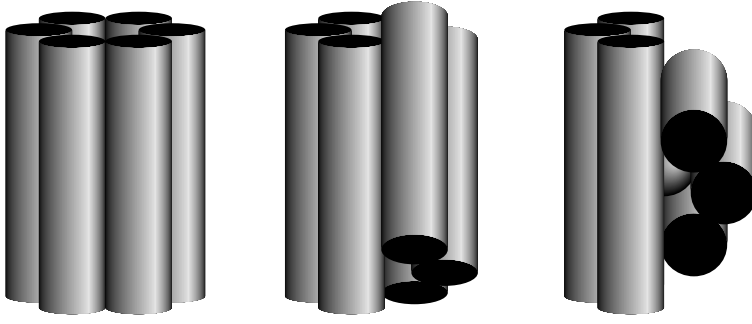

Figure 2.

2. The Result

Theorem: The maximum number of infinite unit-radius cylinders touching a unit-radius ball in a packing is at most seven.

Proof: Assume there are eight cylinders touching the central ball. Since they are disjoint, also their intersections with any sphere concentric with the central ball must be disjoint. But this is impossible since each touching cylinder covers more than $\frac{1}{7.32}$ ($> \frac{1}{8}$) of the area of a sphere of radius $\sqrt{4.7}$ concentric with the unit-radius ball: too much for eight disjoint copies.

It remains only to compute this area of the intersection set S of the sphere $\{(x, y, z) \in \mathbb{R}^3 \mid x^2 + y^2 + z^2 = 4.7\}$ and the cylinder $\{(x, y, z) \in \mathbb{R}^3 \mid y^2 + (z - 2)^2 \leq 1\}$. For this we use the trivial parametric representation $z(x, y) := \sqrt{4.7 - x^2 - y^2}$ and the projection of S into the x - y -plane as domain

$$D := \left\{ (x, y) \in \mathbb{R}^2 \mid x^2 + y^2 \leq 4.7 \text{ and } y^2 + (z(x, y) - 2)^2 \leq 1 \right\}$$

Then the area of S is the integral over D of $\frac{1}{|\cos \nu|}$, where ν is the angle between the outer normal of S in $(x, y, z(x, y))$ and the z -axis [1 p.251]; since S is a subset of a sphere, this reduces to

$$\begin{aligned} \text{area}(S) &= \int_D \frac{\sqrt{4.7}}{\sqrt{4.7 - x^2 - y^2}} dx dy \\ &= \int_{-\sqrt{3.7}}^{\sqrt{3.7}} \int_{\frac{1}{4}\sqrt{15.91 - 0.6x^2 - x^4}}^{\frac{1}{4}\sqrt{15.91 - 0.6x^2 - x^4} + \sqrt{4.7 - x^2}} \frac{\sqrt{4.7}}{\sqrt{4.7 - x^2 - y^2}} dy dx \\ &= \sqrt{18.8} \int_{-\sqrt{3.7}}^{\sqrt{3.7}} \arcsin \left(\frac{1}{4} \sqrt{\frac{15.91 - 0.6x^2 - x^4}{4.7 - x^2}} \right) dx. \end{aligned}$$

This integral can be evaluated numerically to any desired accuracy, and gives the claimed bound $\frac{1}{7.32}$ for the area ratio.

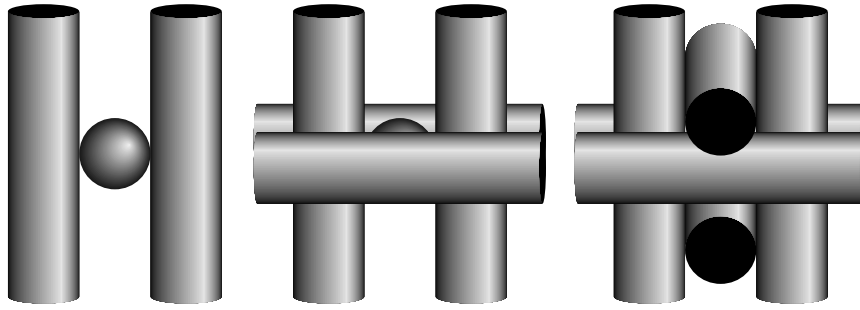

Figure 3.

3. Further Remarks

There seems to be no obvious way to improve this bound from seven to six: the methods of packing theory beyond this trivial area sum statement mostly fail, because the intersection sets which are here packed on a sphere are not (spherically) convex.

In [3] Heppes and Szabó also discuss the same problem for higher dimensions, and for other radii of the touching cylinders (especially thinner cylinders). In both cases this method can be used to obtain bounds; but the second seems to be the more promising problem. Let $n(r)$ be the maximum number of infinite cylinders of radius r that can touch a unit ball in a packing. Our method gives an upper bound $n(r) \leq c_1 r^{-\frac{3}{2}}$, and they observe a lower bound of $n(r) \geq c_2 r^{-1}$ generalizing the six-cylinders construction. We believe that the order of magnitude of the lower bound is too small.

4. References

- [1] FICHTENHOLZ, G.M.: ‘Differential- und Integralrechnung III’, VEB Deutscher Verlag der Wissenschaften, Berlin 1974
- [2] C. GRAF and P. PAUKOWITSCH: ‘Möglichst dichte Packungen aus kongruenten Drehzylindern mit paarweise windschiefen Achsen’, *Elemente der Mathematik* **52** (1997) 71-83.
- [3] A. HEPPEES and L. SZABÓ: ‘On the number of cylinders touching a ball’, *Geom. Dedicata* **40** (1991), 111-116.
- [4] K. KUPERBERG: ‘A nonparallel cylinder packing with positive density’, *Mathematika* **37** (1990), 324-331.
- [5] W. KUPERBERG: ‘Problem 3.3’, DIMACS report on Workshop on Polytopes and Convex Sets, Rutgers University 1990.
- [6] L. SZABÓ: ‘On the density of unit balls touching a unit cylinder’, *Arch. Math.* **64** (1995), 459-464.