

# CS 5633 -- Spring 2008

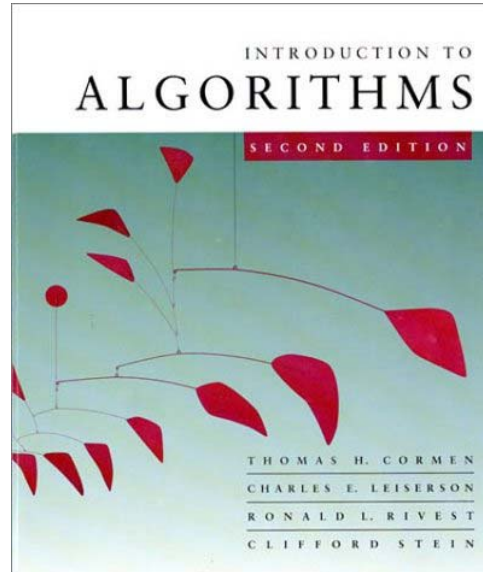

## *Single Source Shortest Paths*

**Carola Wenk**

Slides courtesy of Charles Leiserson with small changes by Carola Wenk

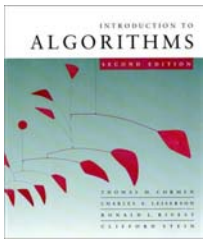

# Paths in graphs

Consider a digraph  $G = (V, E)$  with edge-weight function  $w : E \rightarrow \mathbb{R}$ . The **weight** of path  $p = v_1 \rightarrow v_2 \rightarrow \dots \rightarrow v_k$  is defined to be

$$w(p) = \sum_{i=1}^{k-1} w(v_i, v_{i+1}).$$

**Example:**

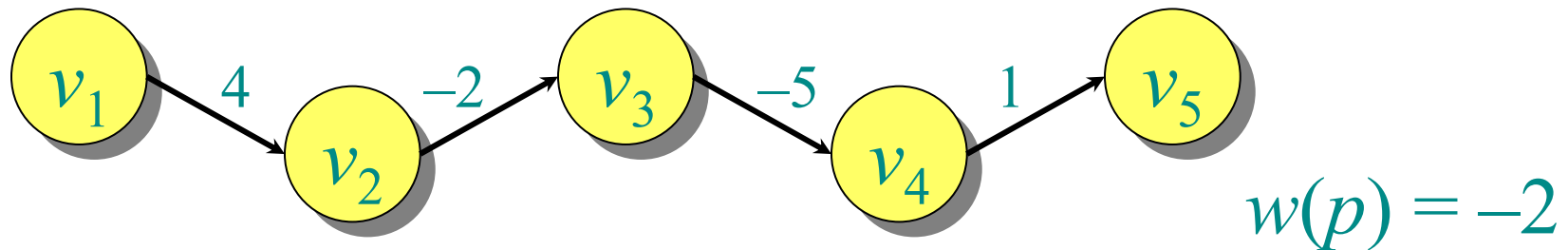

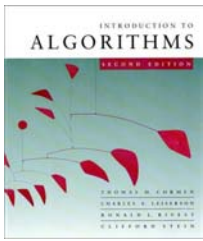

# Shortest paths

A *shortest path* from  $u$  to  $v$  is a path of minimum weight from  $u$  to  $v$ . The *shortest-path weight* from  $u$  to  $v$  is defined as

$$\delta(u, v) = \min\{w(p) : p \text{ is a path from } u \text{ to } v\}.$$

**Note:**  $\delta(u, v) = \infty$  if no path from  $u$  to  $v$  exists.

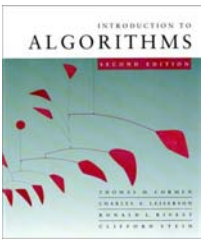

# Optimal substructure

**Theorem.** A subpath of a shortest path is a shortest path.

*Proof.* Cut and paste:

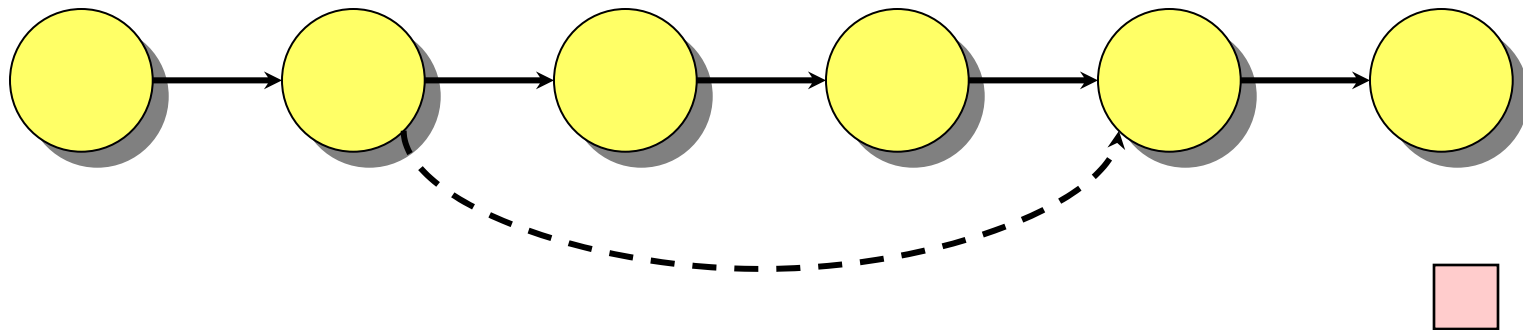

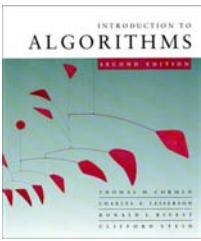

# Triangle inequality

**Theorem.** For all  $u, v, x \in V$ , we have  
$$\delta(u, v) \leq \delta(u, x) + \delta(x, v).$$

*Proof.*

- $\delta(u, v)$  minimizes over **all** paths from  $u$  to  $v$
- Concatenating two shortest paths from  $u$  to  $x$  and from  $x$  to  $v$  yields **one** specific path from  $u$  to  $v$

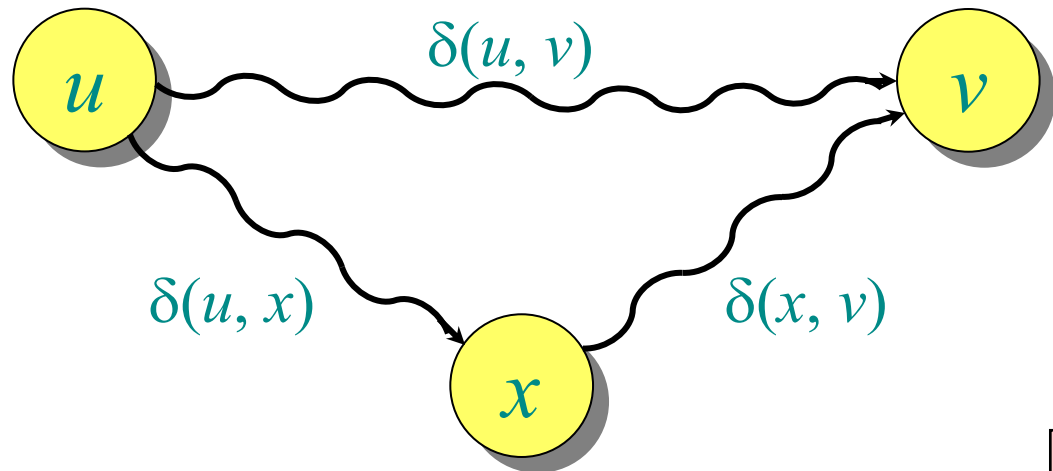

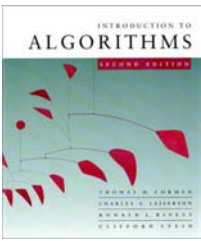

# Well-definedness of shortest paths

If a graph  $G$  contains a negative-weight cycle, then some shortest paths may not exist.

**Example:**

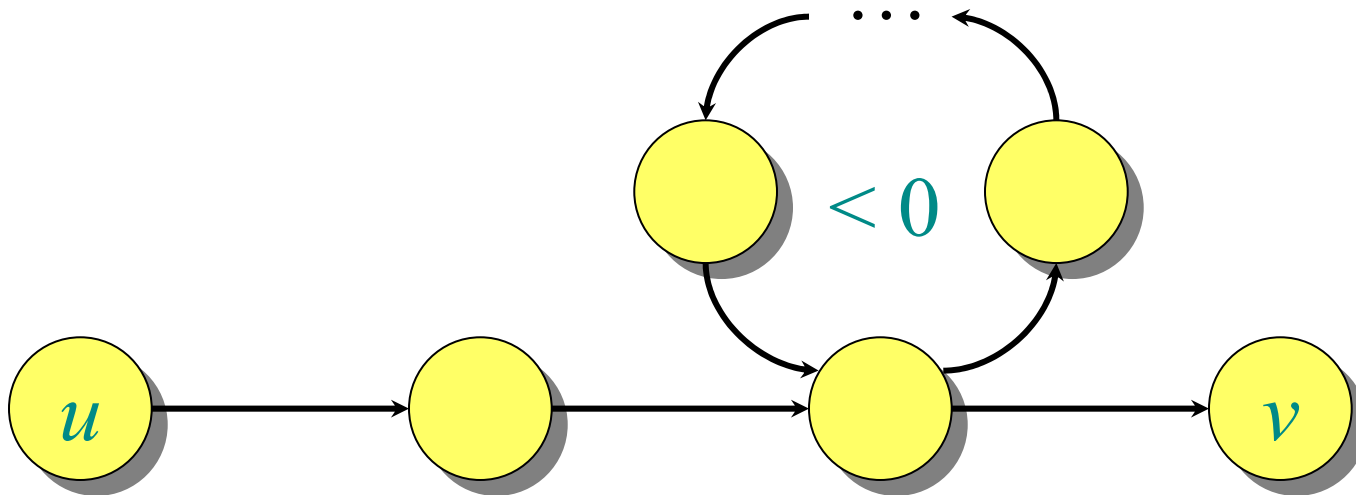

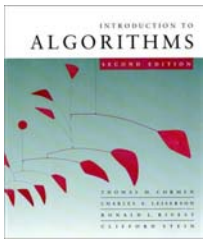

# Single-source shortest paths

**Problem.** From a given source vertex  $s \in V$ , find the shortest-path weights  $\delta(s, v)$  for all  $v \in V$ .

If all edge weights  $w(u, v)$  are *nonnegative*, all shortest-path weights must exist.

**IDEA:** Greedy.

1. Maintain a set  $S$  of vertices whose shortest-path weights from  $s$  are known.
2. At each step add to  $S$  the vertex  $v \in V - S$  whose distance estimate from  $s$  is minimal.
3. Update the distance estimates of vertices adjacent to  $v$ .

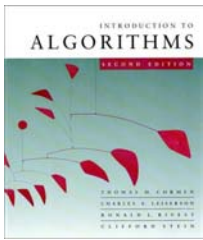

# Dijkstra's algorithm

$d[s] \leftarrow 0$

**for** each  $v \in V - \{s\}$

**do**  $d[v] \leftarrow \infty$

$S \leftarrow \emptyset$

$Q \leftarrow V$  ▷  $Q$  is a priority queue maintaining  $V - S$

**while**  $Q \neq \emptyset$  **do**

$u \leftarrow \text{EXTRACT-MIN}(Q)$

$S \leftarrow S \cup \{u\}$

**for** each  $v \in \text{Adj}[u]$  **do**

**if**  $d[v] > d[u] + w(u, v)$  **then**

$d[v] \leftarrow d[u] + w(u, v)$

*relaxation  
step*

↑  
Implicit DECREASE-KEY

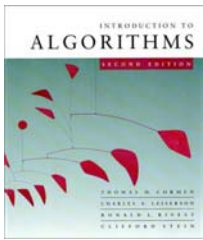

# Dijkstra

$d[s] \leftarrow 0$   
**for each**  $v \in V - \{s\}$   
     **do**  $d[v] \leftarrow \infty$   
 $S \leftarrow \emptyset$   
 $Q \leftarrow V$  ▷  $Q$  is  $V$   
**while**  $Q \neq \emptyset$  **do**

$u \leftarrow \text{EXTRACT-MIN}(Q)$   
 $S \leftarrow S \cup \{u\}$   
**for each**  $v \in \text{Adj}[u]$  **do**

**if**  $d[v] > d[u] + w(u, v)$  **then**  
      $d[v] \leftarrow d[u] + w(u, v)$

↑  
Implicit DECREASE-KEY

**PRIM's algorithm**

$Q \leftarrow V$   
 $key[v] \leftarrow \infty$  for all  $v \in V$   
 $key[s] \leftarrow 0$  for some arbitrary  $s \in V$   
**while**  $Q \neq \emptyset$   
     **do**  $u \leftarrow \text{EXTRACT-MIN}(Q)$   
         **for each**  $v \in \text{Adj}[u]$   
             **do if**  $v \in Q$  and  $w(u, v) < key[v]$   
                 **then**  $key[v] \leftarrow w(u, v)$   
                      $\pi[v] \leftarrow u$

It suffices to only check  $v \in Q$ , but it doesn't hurt to check all  $v$

*relaxation  
step*

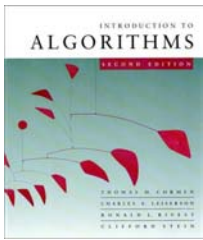

# Example of Dijkstra's algorithm

Graph with nonnegative edge weights:

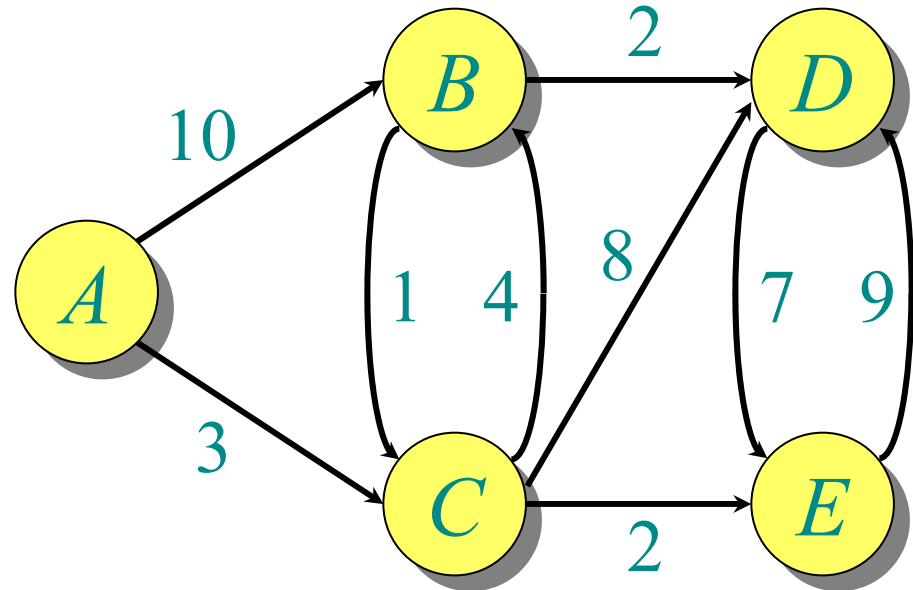

```
while  $Q \neq \emptyset$  do
   $u \leftarrow \text{EXTRACT-MIN}(Q)$ 
   $S \leftarrow S \cup \{u\}$ 
  for each  $v \in \text{Adj}[u]$  do
    if  $d[v] > d[u] + w(u, v)$  then
       $d[v] \leftarrow d[u] + w(u, v)$ 
```

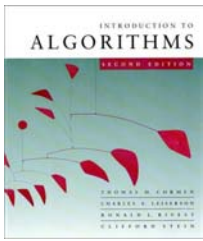

# Example of Dijkstra's algorithm

**Initialize:**

$S: \{\}$

$Q:$

$A$	$B$	$C$	$D$	$E$
0	$\infty$	$\infty$	$\infty$	$\infty$

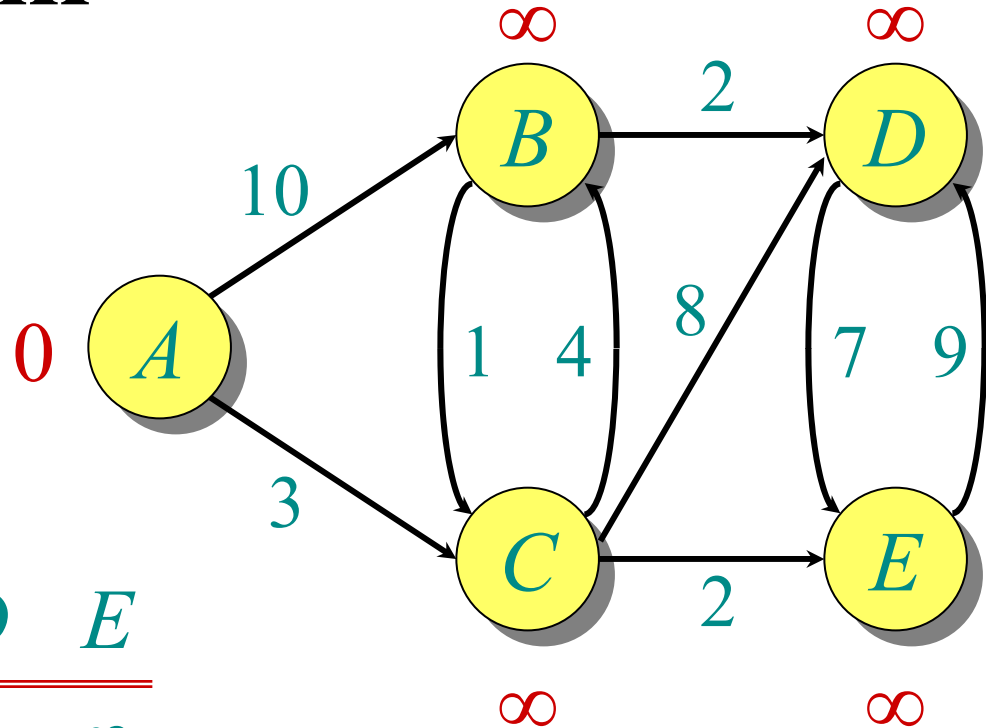

```
while  $Q \neq \emptyset$  do
   $u \leftarrow \text{EXTRACT-MIN}(Q)$ 
   $S \leftarrow S \cup \{u\}$ 
  for each  $v \in \text{Adj}[u]$  do
    if  $d[v] > d[u] + w(u, v)$  then
       $d[v] \leftarrow d[u] + w(u, v)$ 
```

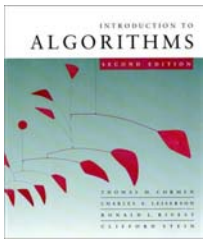

# Example of Dijkstra's algorithm

“A” ← **EXTRACT-MIN**(Q):

S: { A }

Q:	A	B	C	D	E
	0	$\infty$	$\infty$	$\infty$	$\infty$

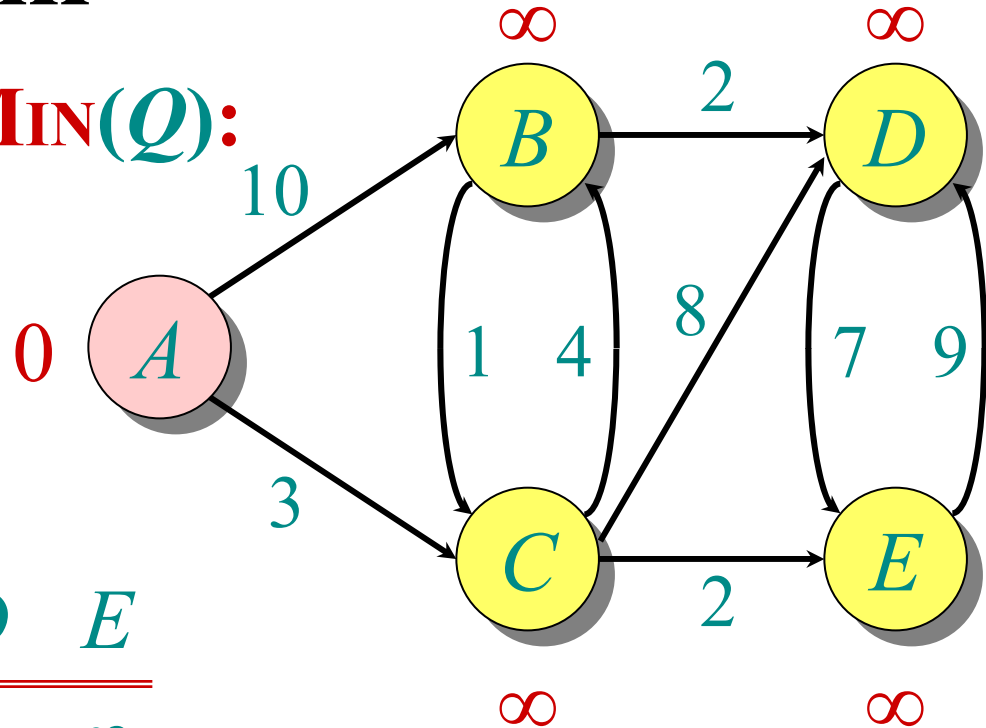

```
while  $Q \neq \emptyset$  do
   $u \leftarrow \text{EXTRACT-MIN}(Q)$ 
   $S \leftarrow S \cup \{u\}$ 
  for each  $v \in \text{Adj}[u]$  do
    if  $d[v] > d[u] + w(u, v)$  then
       $d[v] \leftarrow d[u] + w(u, v)$ 
```

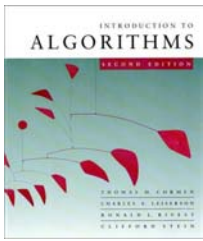

# Example of Dijkstra's algorithm

Relax all edges leaving  $A$ :

$S: \{A\}$

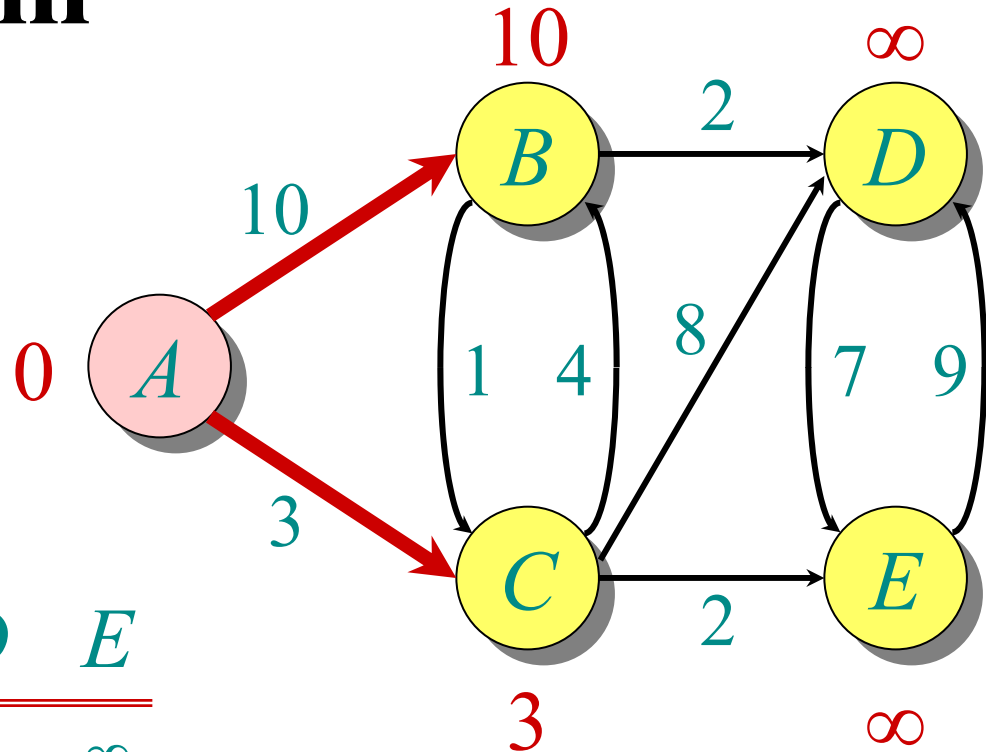

$Q:$	$A$	$B$	$C$	$D$	$E$
	0	$\infty$	$\infty$	$\infty$	$\infty$
		10	3	-	-

```

while  $Q \neq \emptyset$  do
   $u \leftarrow \text{EXTRACT-MIN}(Q)$ 
   $S \leftarrow S \cup \{u\}$ 
  for each  $v \in \text{Adj}[u]$  do
    if  $d[v] > d[u] + w(u, v)$  then
       $d[v] \leftarrow d[u] + w(u, v)$ 
  
```

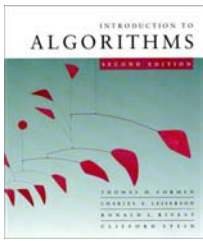

# Example of Dijkstra's algorithm

“C” ← EXTRACT-MIN(Q):

S: { A, C }

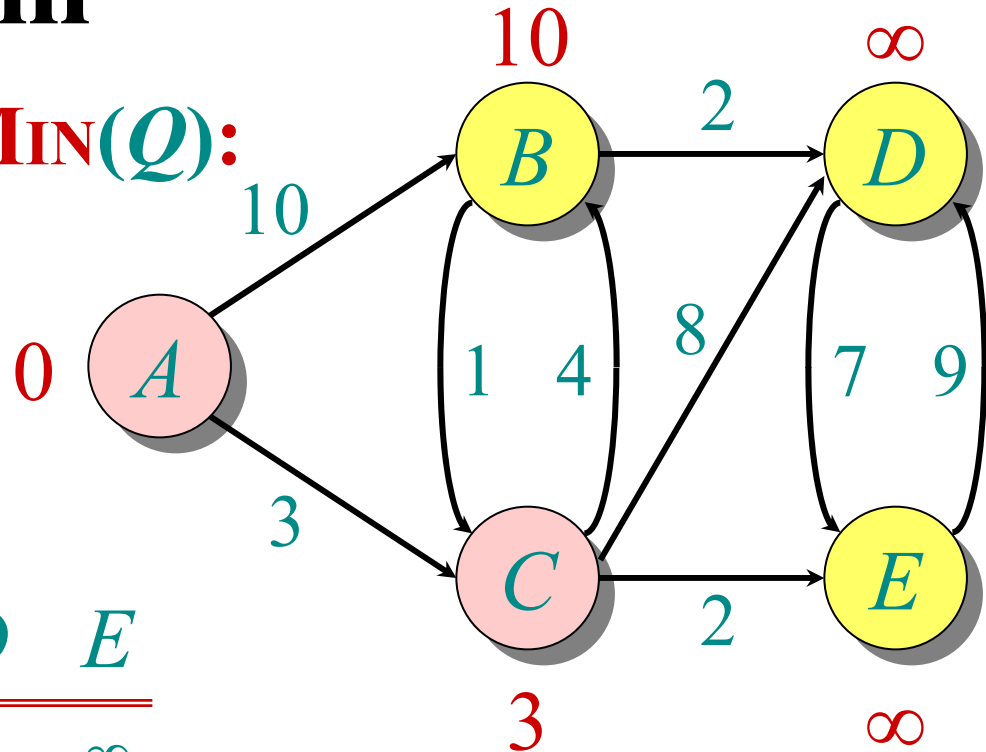

Q:	A	B	C	D	E
	0	∞	∞	∞	∞
		10	3	-	-

```

while Q ≠ ∅ do
  u ← EXTRACT-MIN(Q)
  S ← S ∪ {u}
  for each v ∈ Adj[u] do
    if d[v] > d[u] + w(u, v) then
      d[v] ← d[u] + w(u, v)
  
```

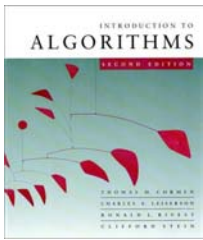

# Example of Dijkstra's algorithm

Relax all edges leaving  $C$ :

$S: \{A, C\}$

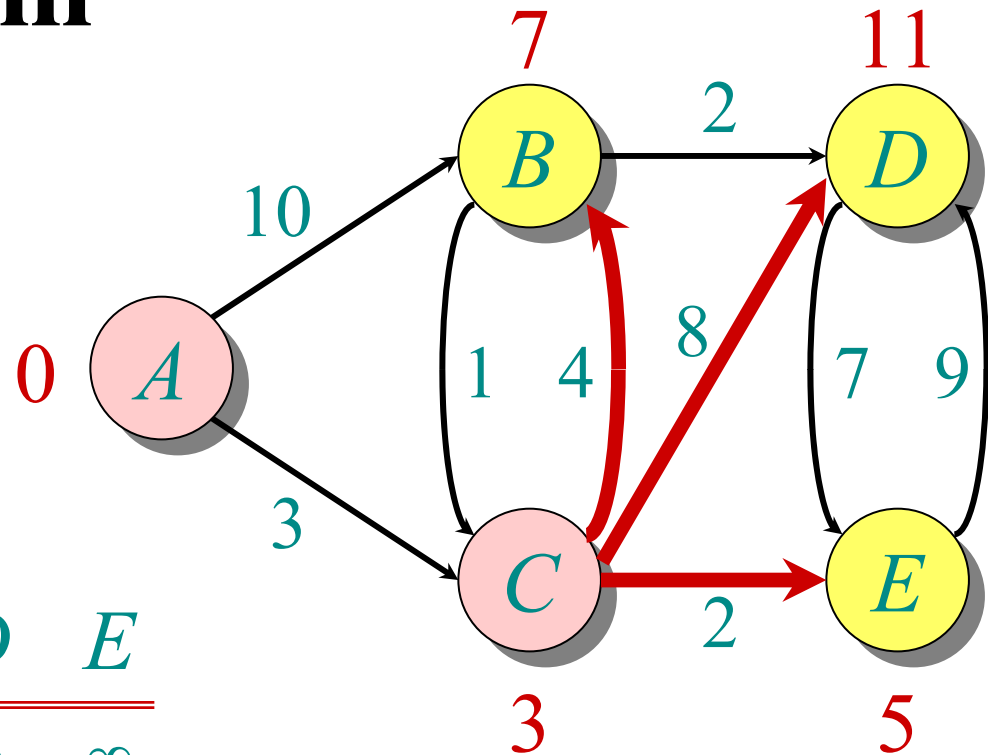

$Q:$

$A$	$B$	$C$	$D$	$E$
0	$\infty$	$\infty$	$\infty$	$\infty$
	10	3	—	—
	7		11	5

```

while  $Q \neq \emptyset$  do
   $u \leftarrow \text{EXTRACT-MIN}(Q)$ 
   $S \leftarrow S \cup \{u\}$ 
  for each  $v \in \text{Adj}[u]$  do
    if  $d[v] > d[u] + w(u, v)$  then
       $d[v] \leftarrow d[u] + w(u, v)$ 
  
```

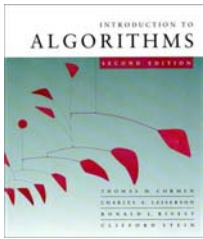

# Example of Dijkstra's algorithm

“E” ← **EXTRACT-MIN**(Q):

S: { A, C, E }

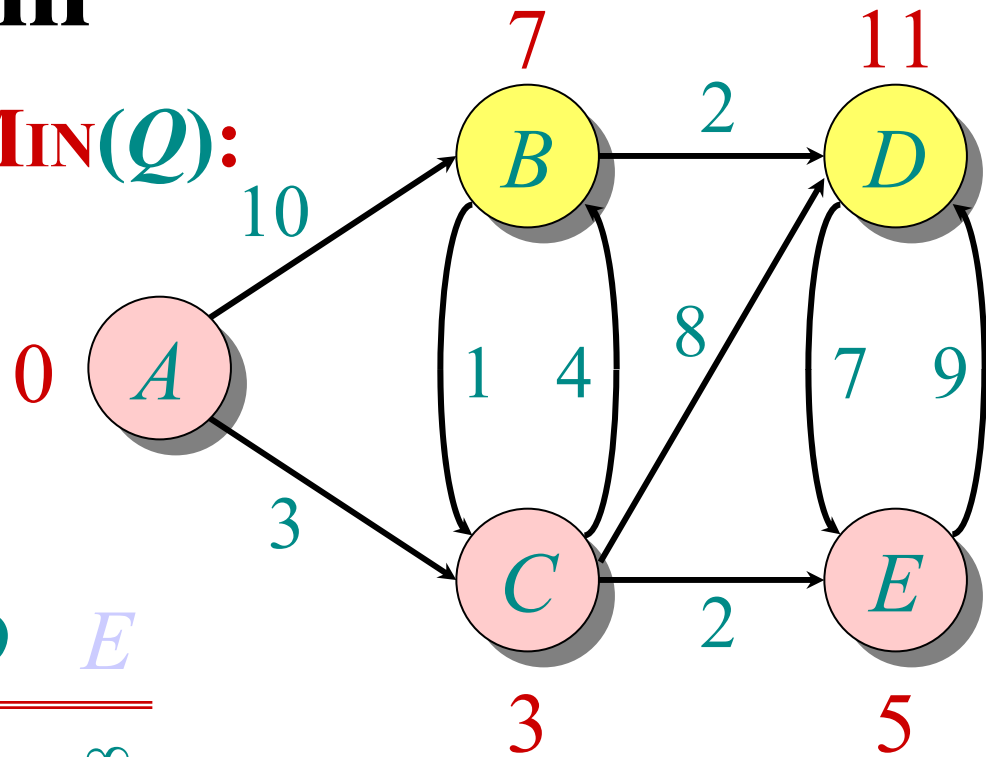

Q:	A	B	C	D	E
	0	$\infty$	$\infty$	$\infty$	$\infty$
		10	3	–	–
		7		11	5

```

while  $Q \neq \emptyset$  do
   $u \leftarrow$  EXTRACT-MIN(Q)
   $S \leftarrow S \cup \{u\}$ 
  for each  $v \in Adj[u]$  do
    if  $d[v] > d[u] + w(u, v)$  then
       $d[v] \leftarrow d[u] + w(u, v)$ 
  
```

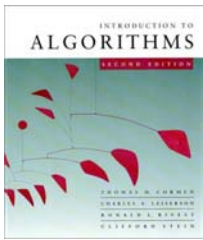

# Example of Dijkstra's algorithm

Relax all edges leaving  $E$ :

$S: \{A, C, E\}$

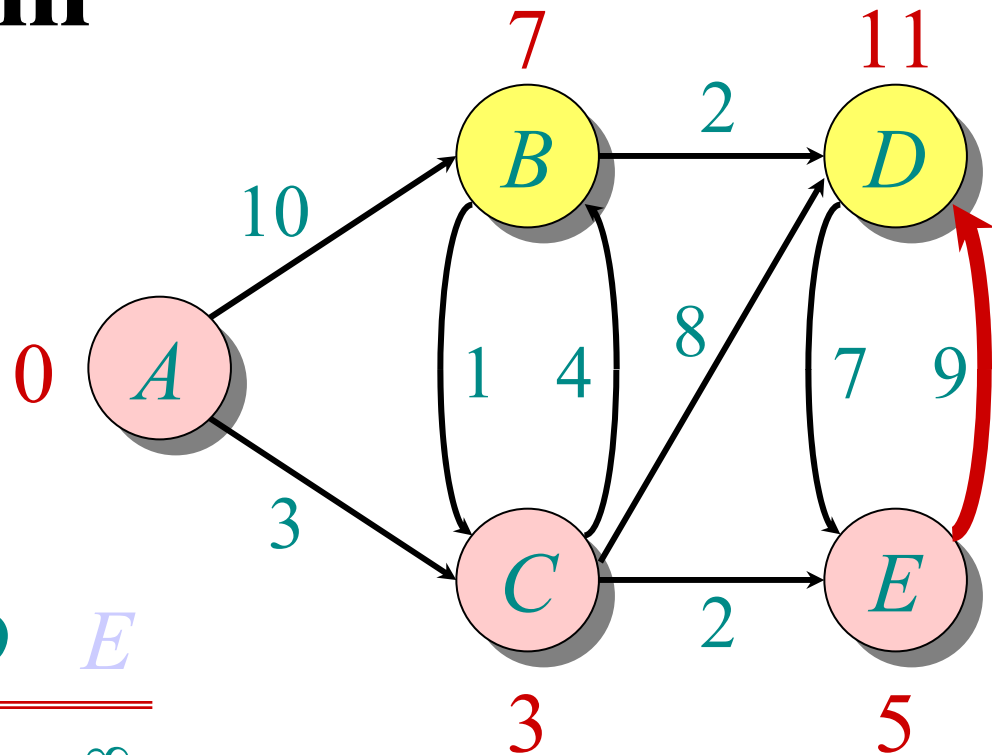

$Q:$

$A$	$B$	$C$	$D$	$E$
0	$\infty$	$\infty$	$\infty$	$\infty$
	10	3	$\infty$	$\infty$
	7		11	5
	7		11	

```

while  $Q \neq \emptyset$  do
   $u \leftarrow \text{EXTRACT-MIN}(Q)$ 
   $S \leftarrow S \cup \{u\}$ 
  for each  $v \in \text{Adj}[u]$  do
    if  $d[v] > d[u] + w(u, v)$  then
       $d[v] \leftarrow d[u] + w(u, v)$ 
  
```

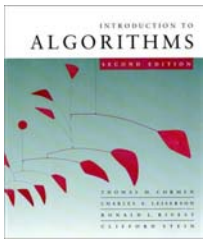

# Example of Dijkstra's algorithm

“B” ← **EXTRACT-MIN**(Q):

S: { A, C, E, B }    0

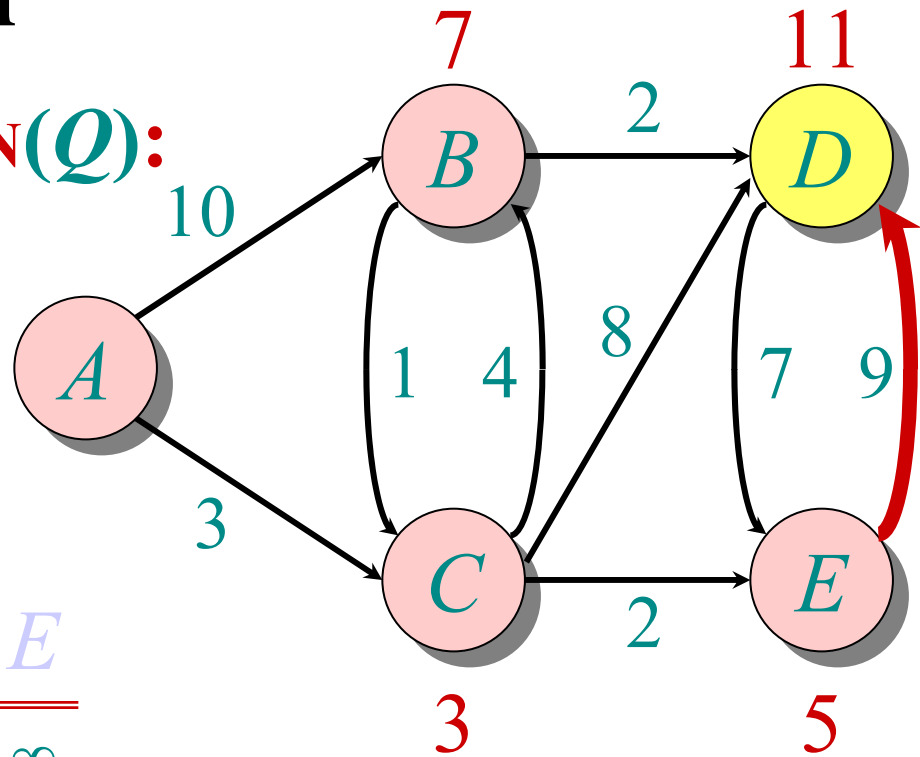

Q:

A	B	C	D	E
0	$\infty$	$\infty$	$\infty$	$\infty$
10	3	$\infty$	$\infty$	$\infty$
7		11	5	
7		11		

```

while Q ≠ ∅ do
  u ← EXTRACT-MIN(Q)
  S ← S ∪ {u}
  for each v ∈ Adj[u] do
    if d[v] > d[u] + w(u, v) then
      d[v] ← d[u] + w(u, v)
  
```

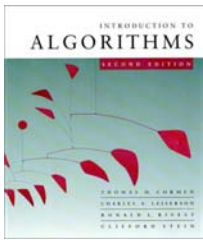

# Example of Dijkstra's algorithm

Relax all edges leaving  $B$ :

$S: \{A, C, E, B\}$      0

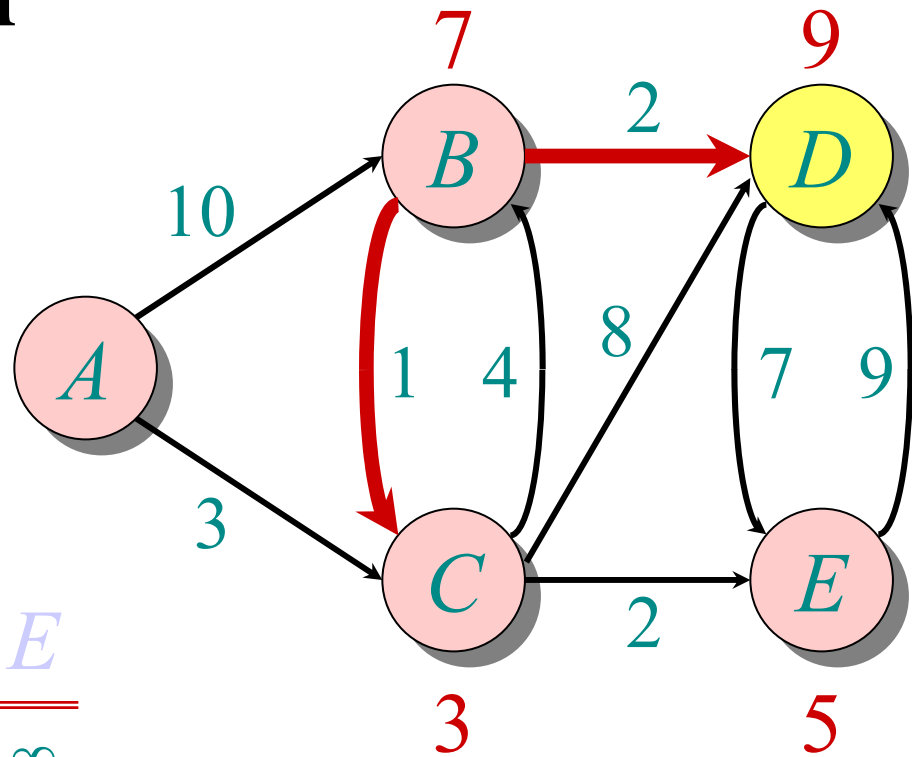

$Q:$

$A$	$B$	$C$	$D$	$E$
0	$\infty$	$\infty$	$\infty$	$\infty$
10	3	$\infty$	$\infty$	$\infty$
7		11	5	
7		11		
		9		

```

while  $Q \neq \emptyset$  do
   $u \leftarrow \text{EXTRACT-MIN}(Q)$ 
   $S \leftarrow S \cup \{u\}$ 
  for each  $v \in \text{Adj}[u]$  do
    if  $d[v] > d[u] + w(u, v)$  then
       $d[v] \leftarrow d[u] + w(u, v)$ 
  
```

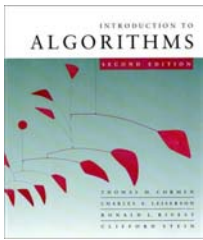

# Example of Dijkstra's algorithm

“D” ← **EXTRACT-MIN**(Q):

S: { A, C, E, B, D } 0

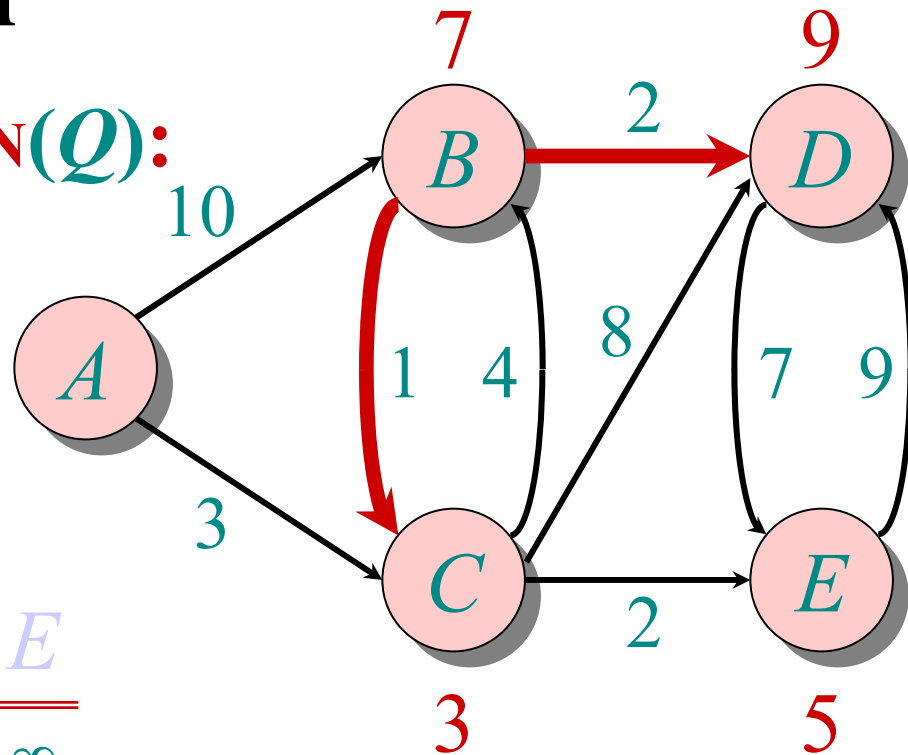

Q:

A	B	C	D	E
0	∞	∞	∞	∞
10	3	∞	∞	∞
7		11	5	
7		11		
		9		

```

while Q ≠ ∅ do
  u ← EXTRACT-MIN(Q)
  S ← S ∪ {u}
  for each v ∈ Adj[u] do
    if d[v] > d[u] + w(u, v) then
      d[v] ← d[u] + w(u, v)
  
```

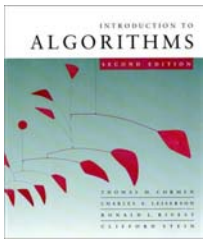

# Analysis of Dijkstra

$|V|$  times {  $degree(u)$  times { while  $Q \neq \emptyset$  do  
     $u \leftarrow \text{EXTRACT-MIN}(Q)$   
     $S \leftarrow S \cup \{u\}$   
    for each  $v \in \text{Adj}[u]$  do  
        if  $d[v] > d[u] + w(u, v)$  then  
             $d[v] \leftarrow d[u] + w(u, v)$

Handshaking Lemma  $\Rightarrow \Theta(|E|)$  implicit DECREASE-KEY's.

$$\text{Time} = \Theta(|V|) \cdot T_{\text{EXTRACT-MIN}} + \Theta(|E|) \cdot T_{\text{DECREASE-KEY}}$$

**Note:** Same formula as in the analysis of Prim's minimum spanning tree algorithm.

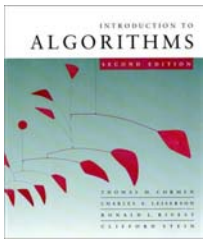

# Analysis of Dijkstra (continued)

$$\text{Time} = \Theta(|V|) \cdot T_{\text{EXTRACT-MIN}} + \Theta(|E|) \cdot T_{\text{DECREASE-KEY}}$$

$Q$	$T_{\text{EXTRACT-MIN}}$	$T_{\text{DECREASE-KEY}}$	Total
-----	--------------------------	---------------------------	-------

array	$O( V )$	$O(1)$	$O( V ^2)$
-------	----------	--------	------------

binary heap	$O(\log  V )$	$O(\log  V )$	$O( E  \log  V )$
----------------	---------------	---------------	-------------------

Fibonacci heap	$O(\log  V )$ amortized	$O(1)$ amortized	$O( E  +  V  \log  V )$ worst case
-------------------	----------------------------	---------------------	---------------------------------------

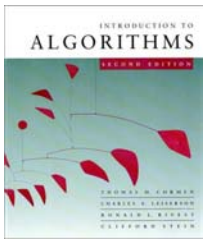

# Correctness

**Theorem.** (i) For all  $v \in S$ :  $d[v] = \delta(s, v)$   
(ii) For all  $v \notin S$ :  $d[v] =$  weight of shortest path from  $s$  to  $v$  that uses only (besides  $v$  itself) vertices in  $S$ .

**Corollary.** Dijkstra's algorithm terminates with  $d[v] = \delta(s, v)$  for all  $v \in V$ .

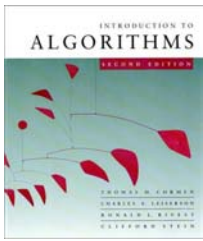

# Correctness

**Theorem.** (i) For all  $v \in S$ :  $d[v] = \delta(s, v)$   
(ii) For all  $v \notin S$ :  $d[v] =$  weight of shortest path from  $s$  to  $v$  that uses only (besides  $v$  itself) vertices in  $S$ .

---

*Proof.* By induction.

- Base: Before the while loop,  $d[s]=0$  and  $d[v]=\infty$  for all  $v \neq s$ , so (i) and (ii) are true.
- Step: Assume (i) and (ii) are true before an iteration; now we need to show they remain true after another iteration. Let  $u$  be the vertex added to  $S$ , so  $d[u] \leq d[v]$  for all other  $v \notin S$ .

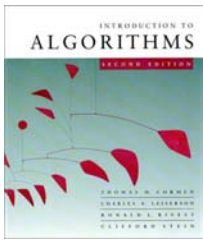

# Correctness

**Theorem.** (i) For all  $v \in S$ :  $d[v] = \delta(s, v)$   
(ii) For all  $v \notin S$ :  $d[v] =$  weight of shortest path from  $s$  to  $v$  that uses only (besides  $v$  itself) vertices in  $S$ .

---

- (i) Need to show that  $d[u] = \delta(s, u)$ . Assume the contrary.  
 $\Rightarrow$  There is a path  $p$  from  $s$  to  $u$  with  $w(p) < d[u]$ . Because of (ii) that path uses vertices  $\notin S$ , in addition to  $u$ .  
 $\Rightarrow$  Let  $y$  be first vertex on  $p$  such that  $y \notin S$ .

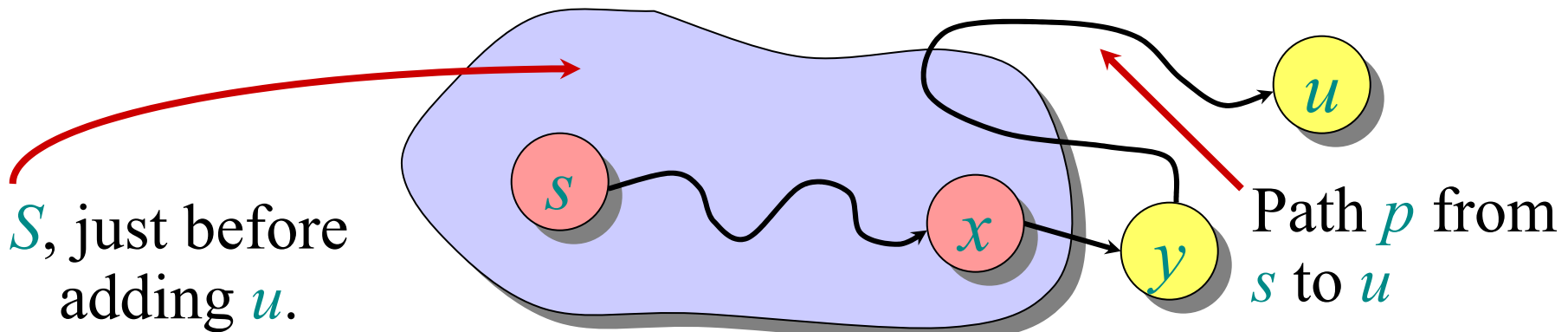

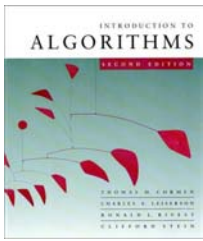

# Correctness

- Theorem.** (i) For all  $v \in S$ :  $d[v] = \delta(s, v)$   
(ii) For all  $v \notin S$ :  $d[v] =$  weight of shortest path from  $s$  to  $v$  that uses only (besides  $v$  itself) vertices in  $S$ .
- 

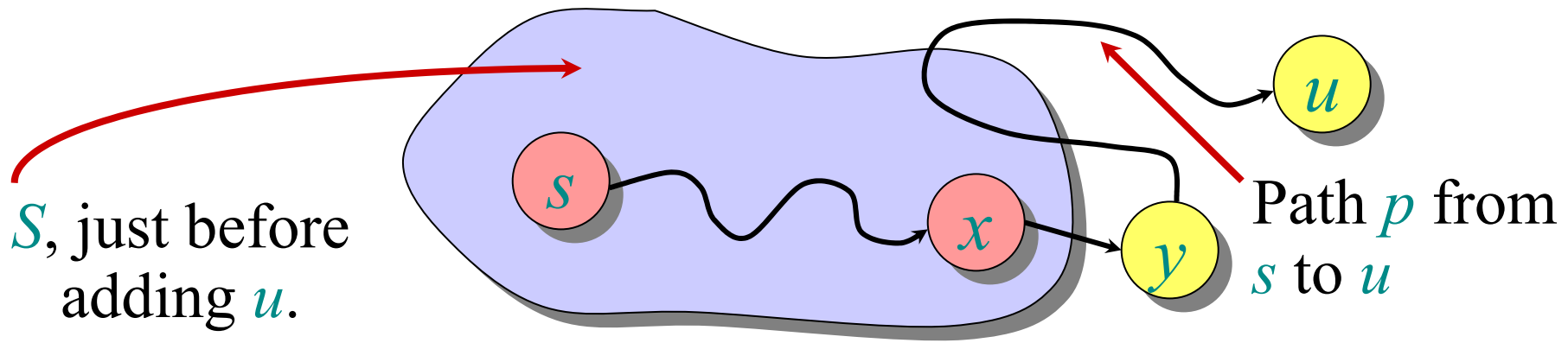

$\Rightarrow d[y] \leq w(p) < d[u]$ . Contradiction to the choice of  $u$ .

weights are nonnegative

assumption about path

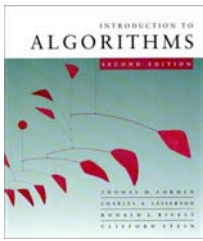

# Correctness

**Theorem.** (i) For all  $v \in S$ :  $d[v] = \delta(s, v)$   
(ii) For all  $v \notin S$ :  $d[v] =$  weight of shortest path from  $s$  to  $v$  that uses only (besides  $v$  itself) vertices in  $S$ .

---

- (ii) Let  $v \notin S$ . Let  $p$  be a shortest path from  $s$  to  $v$  that uses only (besides  $v$  itself) vertices in  $S$ .
  - $p$  does not contain  $u$ : (ii) true by inductive hypothesis
  - $p$  contains  $u$ :  $p$  consists of vertices in  $S \setminus \{u\}$  and ends with an edge from  $u$  to  $v$ .  
 $\Rightarrow w(p) = d[u] + w(u, v)$ , which is the value of  $d[v]$  after adding  $u$ . So (ii) is true.

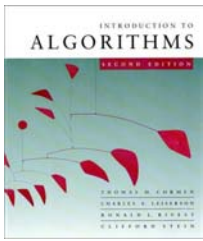

# Unweighted graphs

Suppose  $w(u, v) = 1$  for all  $(u, v) \in E$ . Can the code for Dijkstra be improved?

- Use a simple FIFO queue instead of a priority queue.
- *Breadth-first search*

```
while  $Q \neq \emptyset$ 
  do  $u \leftarrow \text{DEQUEUE}(Q)$ 
    for each  $v \in \text{Adj}[u]$ 
      do if  $d[v] = \infty$ 
          then  $d[v] \leftarrow d[u] + 1$ 
              ENQUEUE( $Q, v$ )
```

**Analysis:** Time =  $O(|V| + |E|)$ .

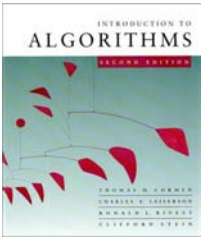

# Example of breadth-first search

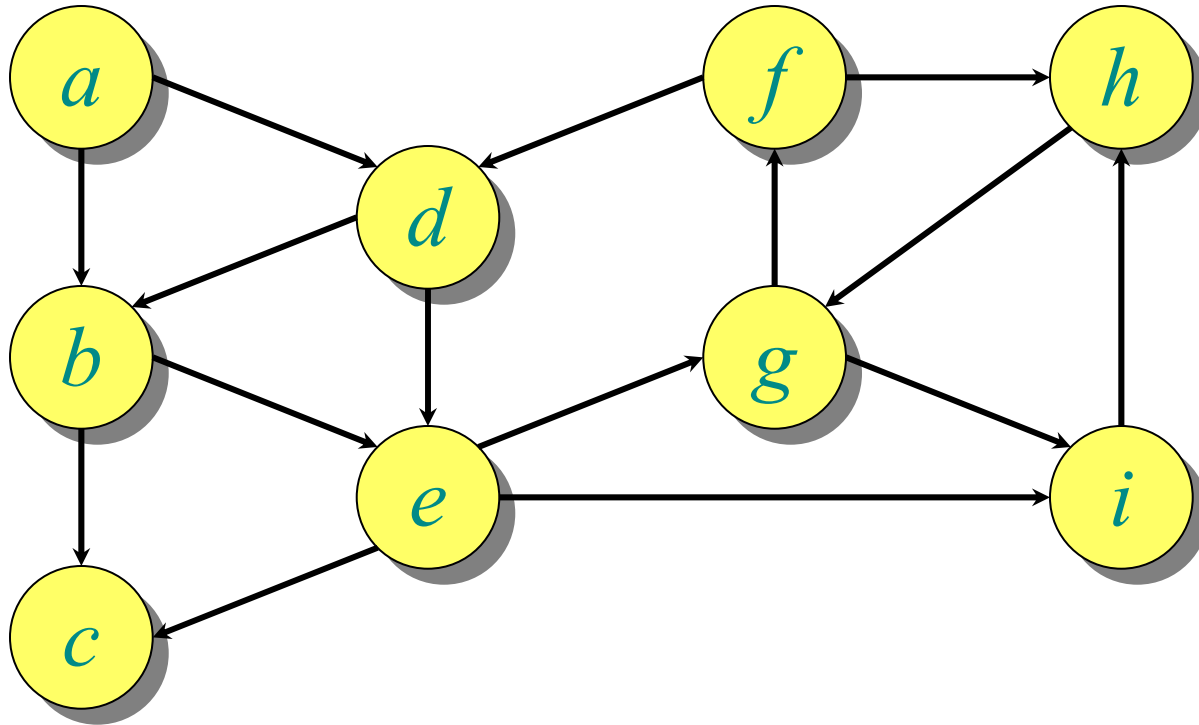

*Q:*

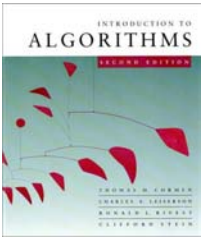

# Example of breadth-first search

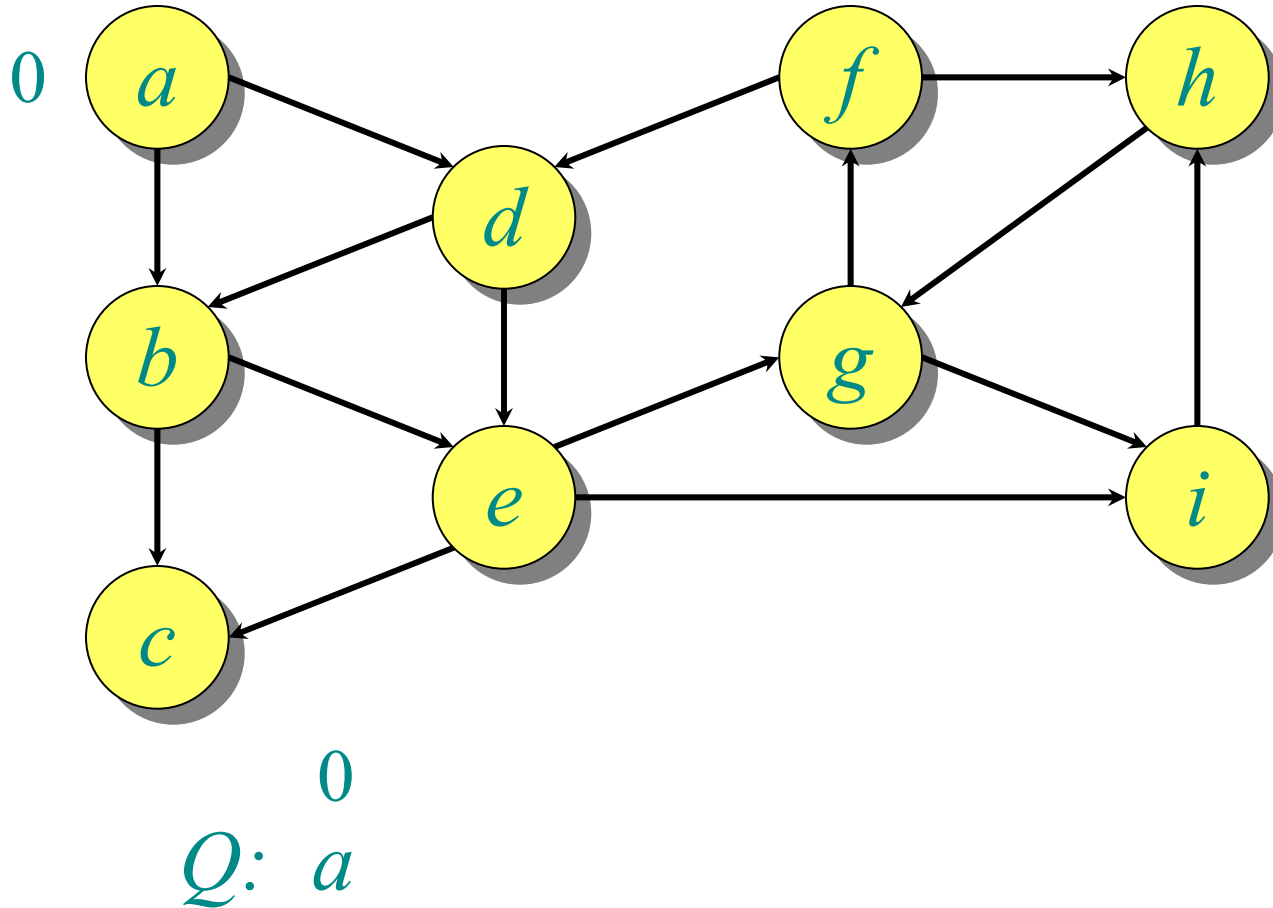

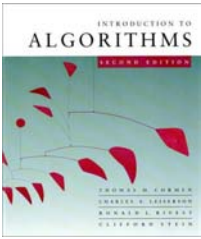

# Example of breadth-first search

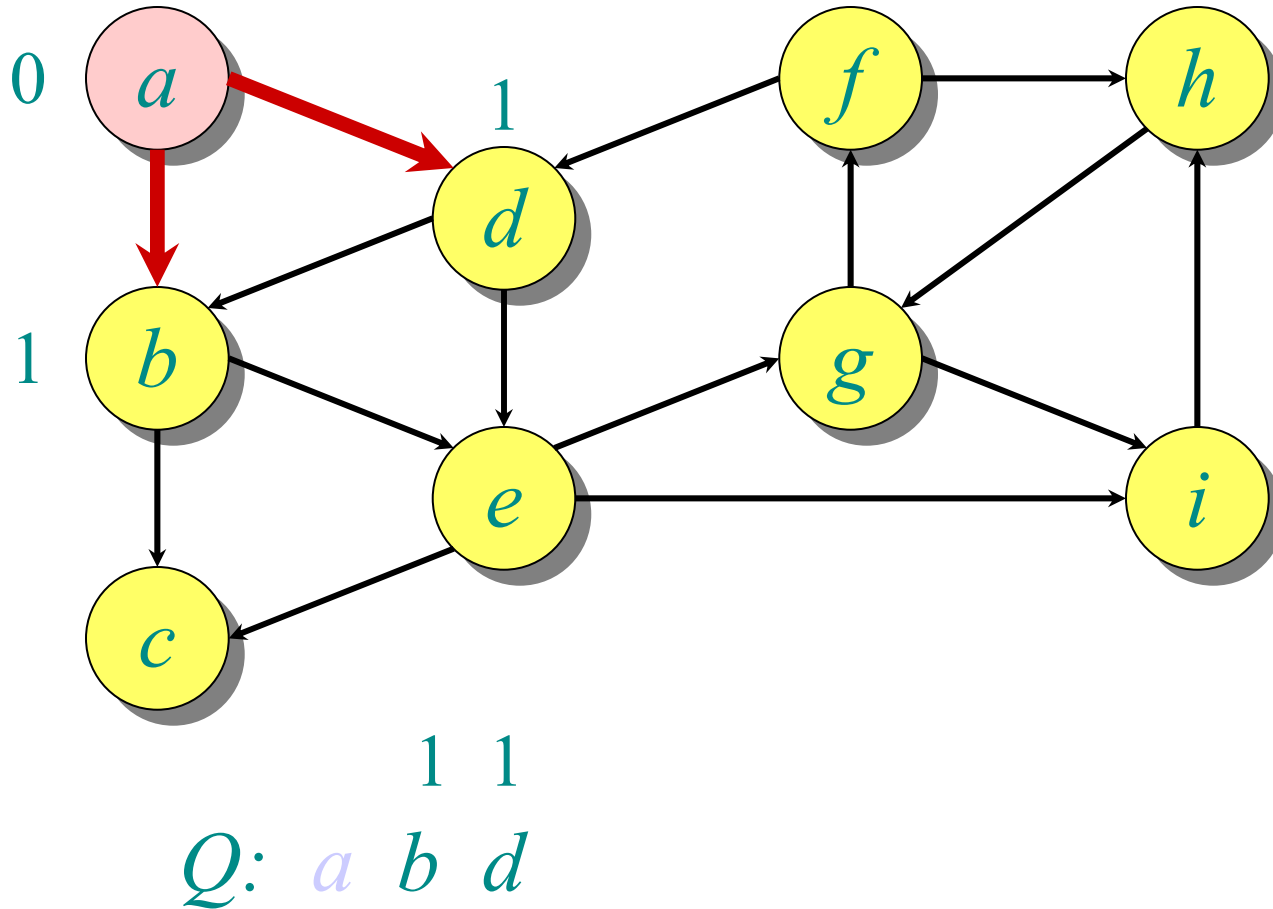

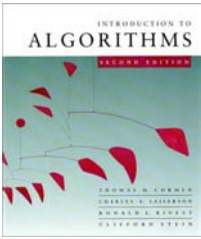

# Example of breadth-first search

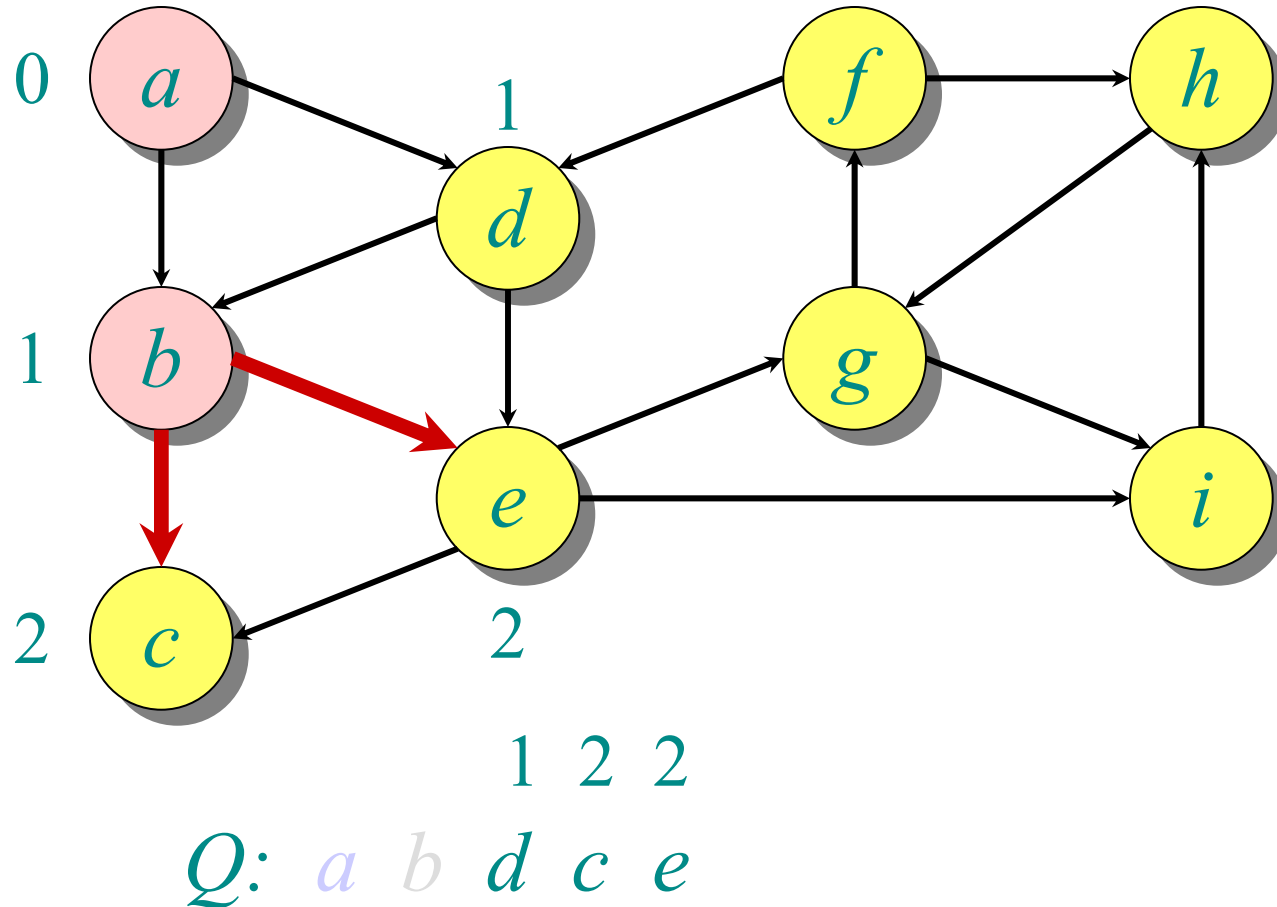

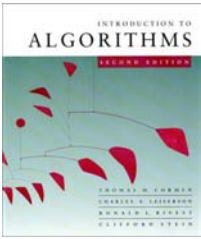

# Example of breadth-first search

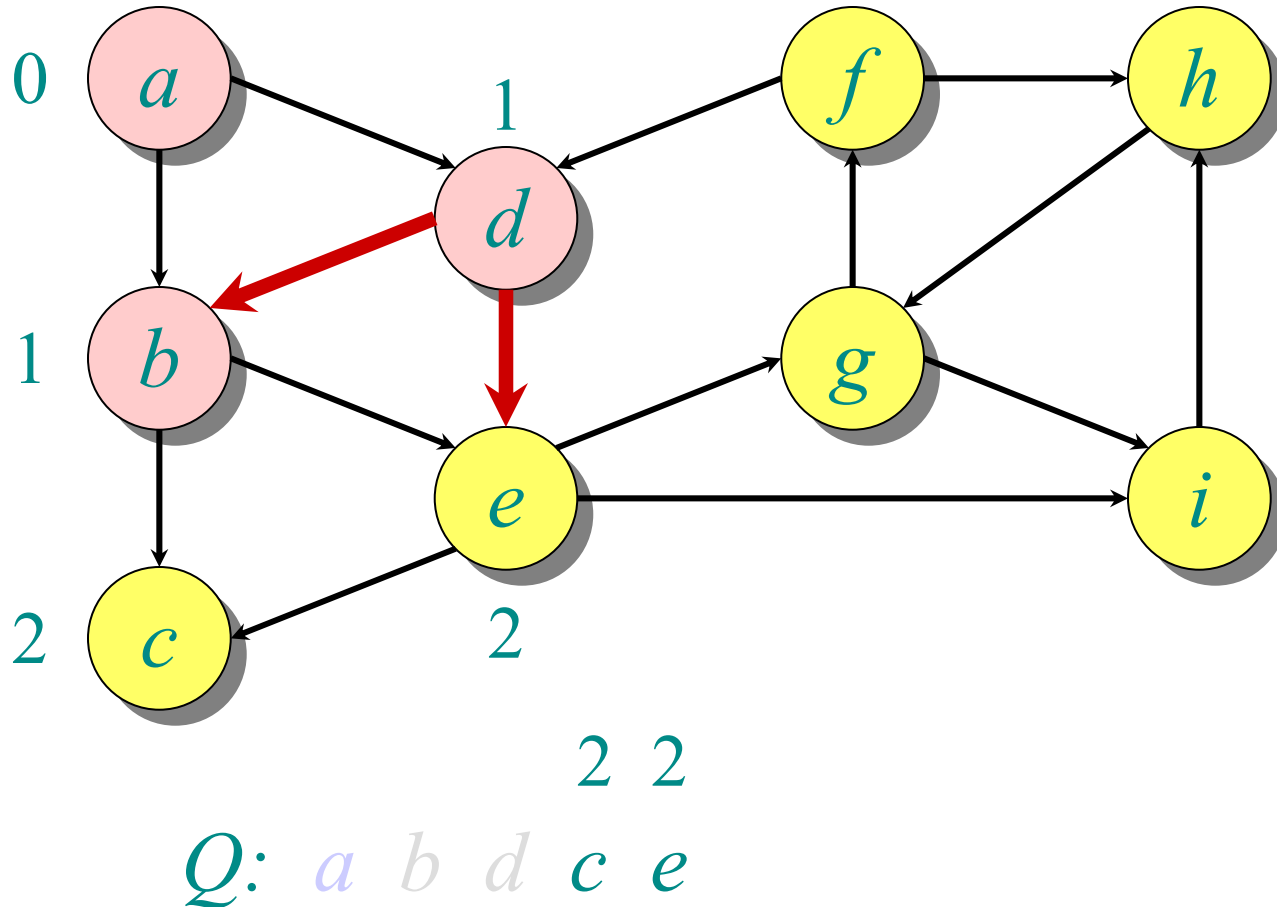

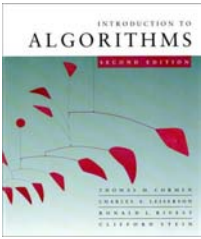

# Example of breadth-first search

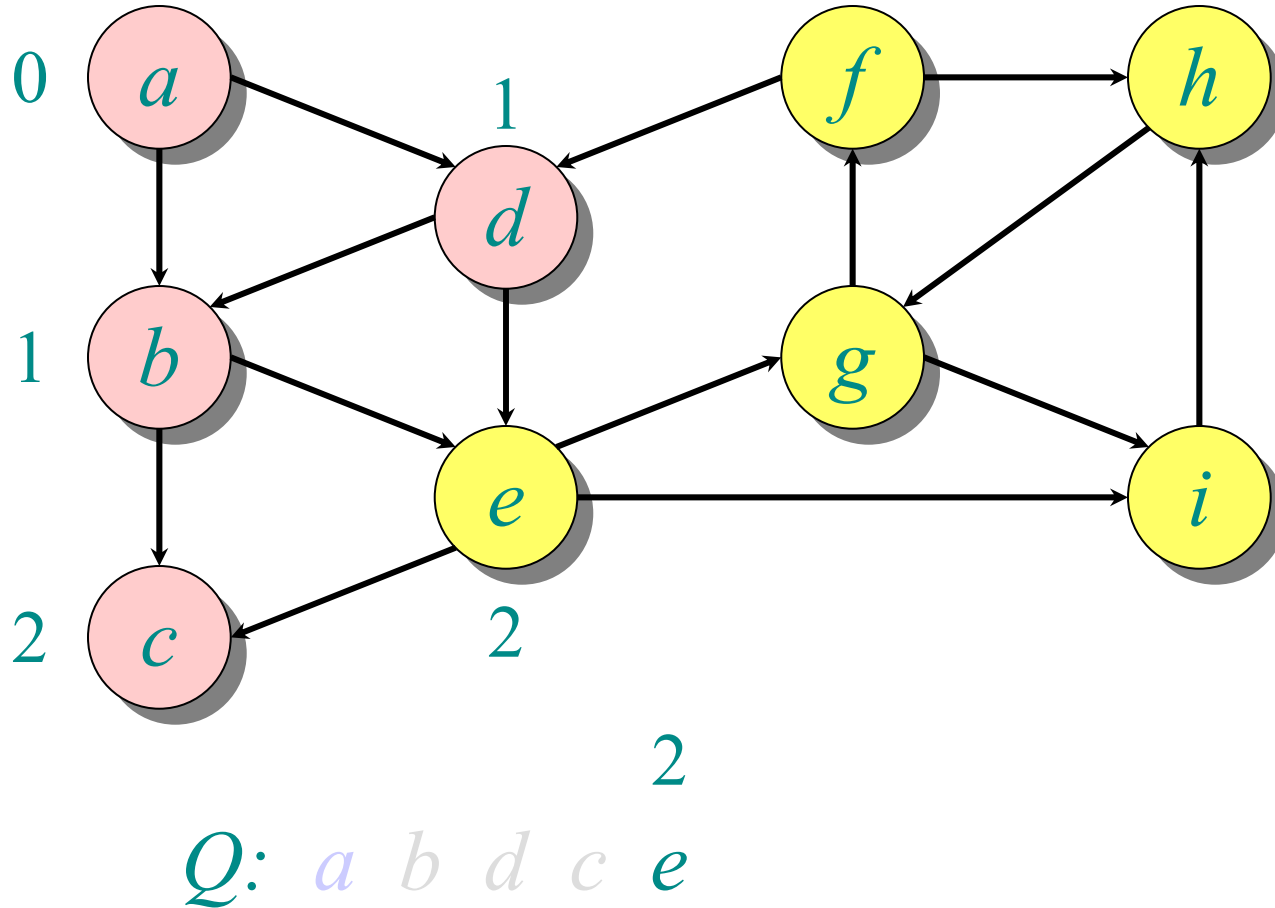

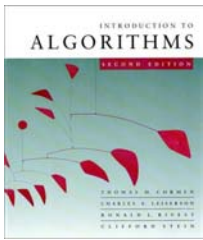

# Example of breadth-first search

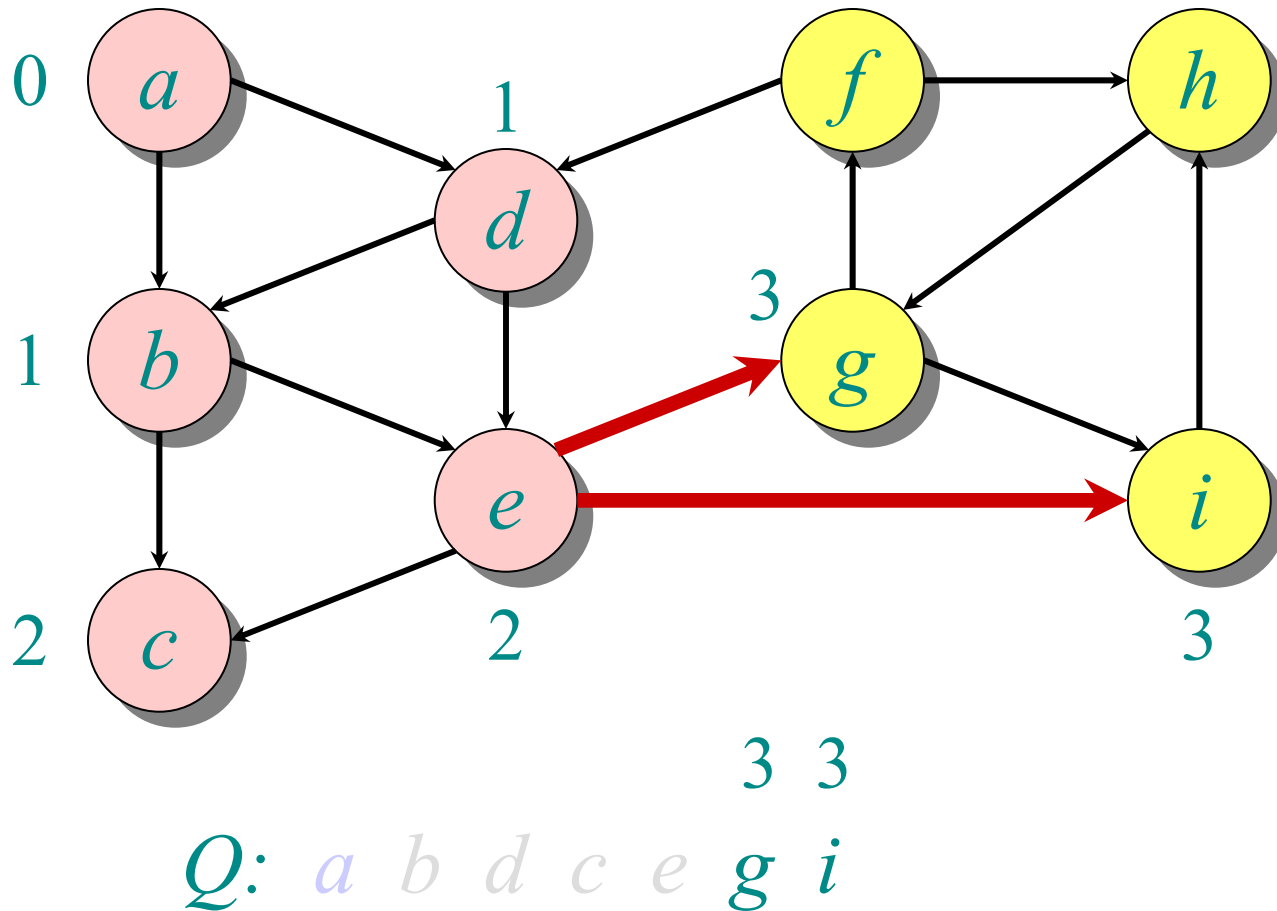

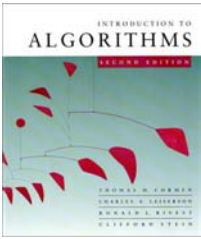

# Example of breadth-first search

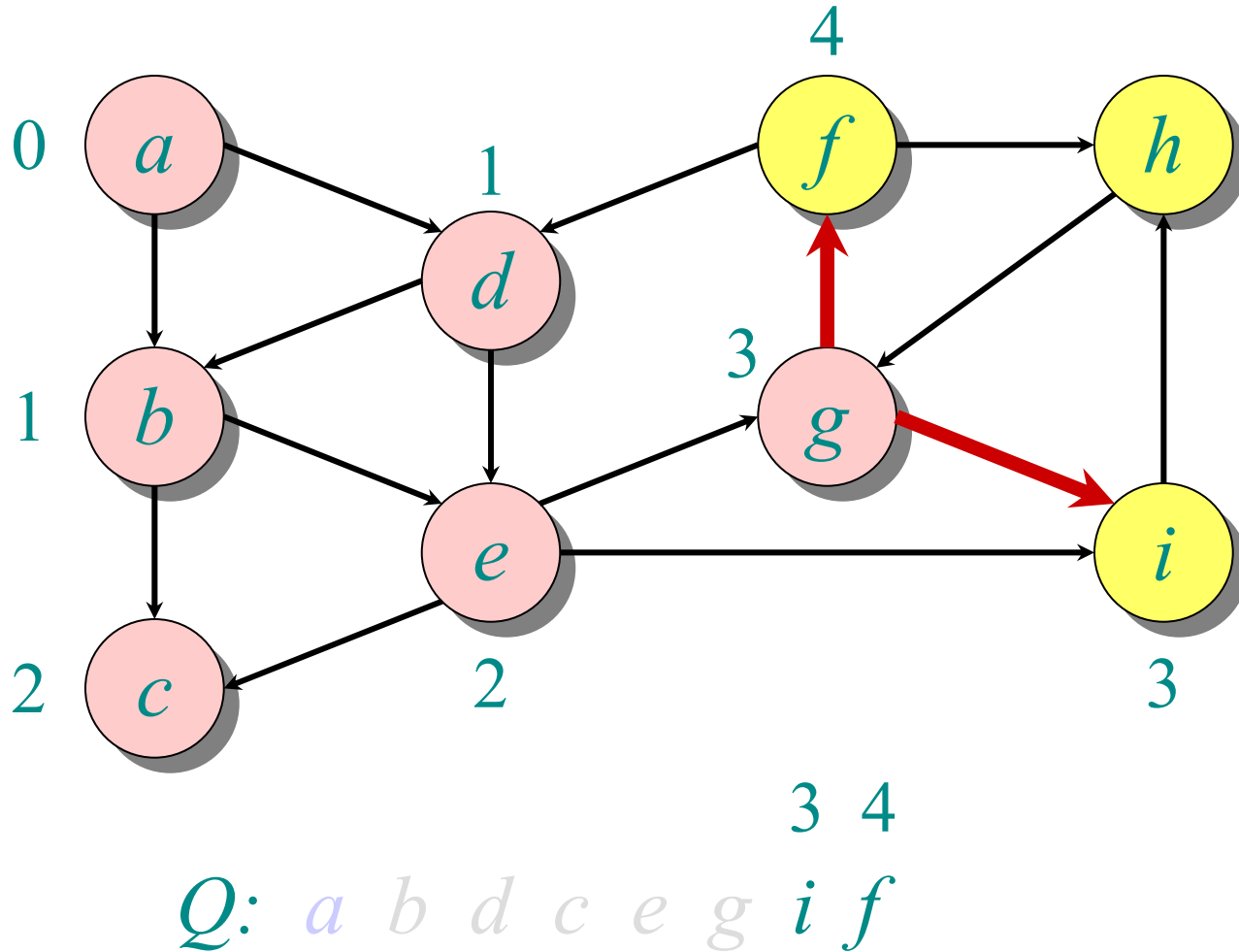

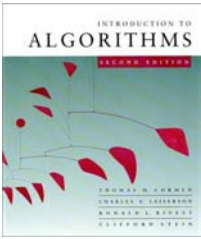

# Example of breadth-first search

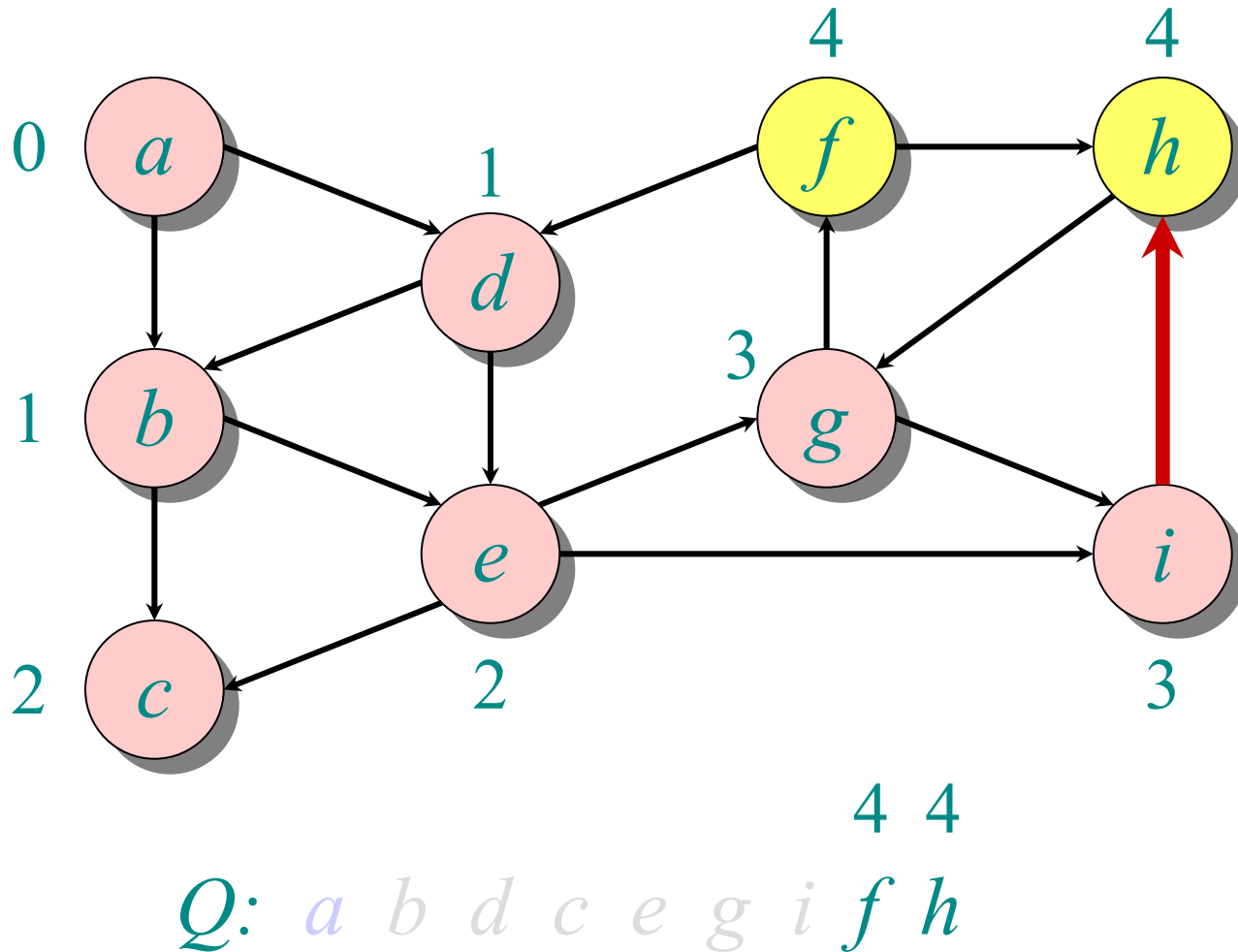

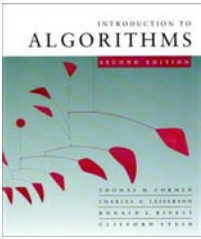

# Example of breadth-first search

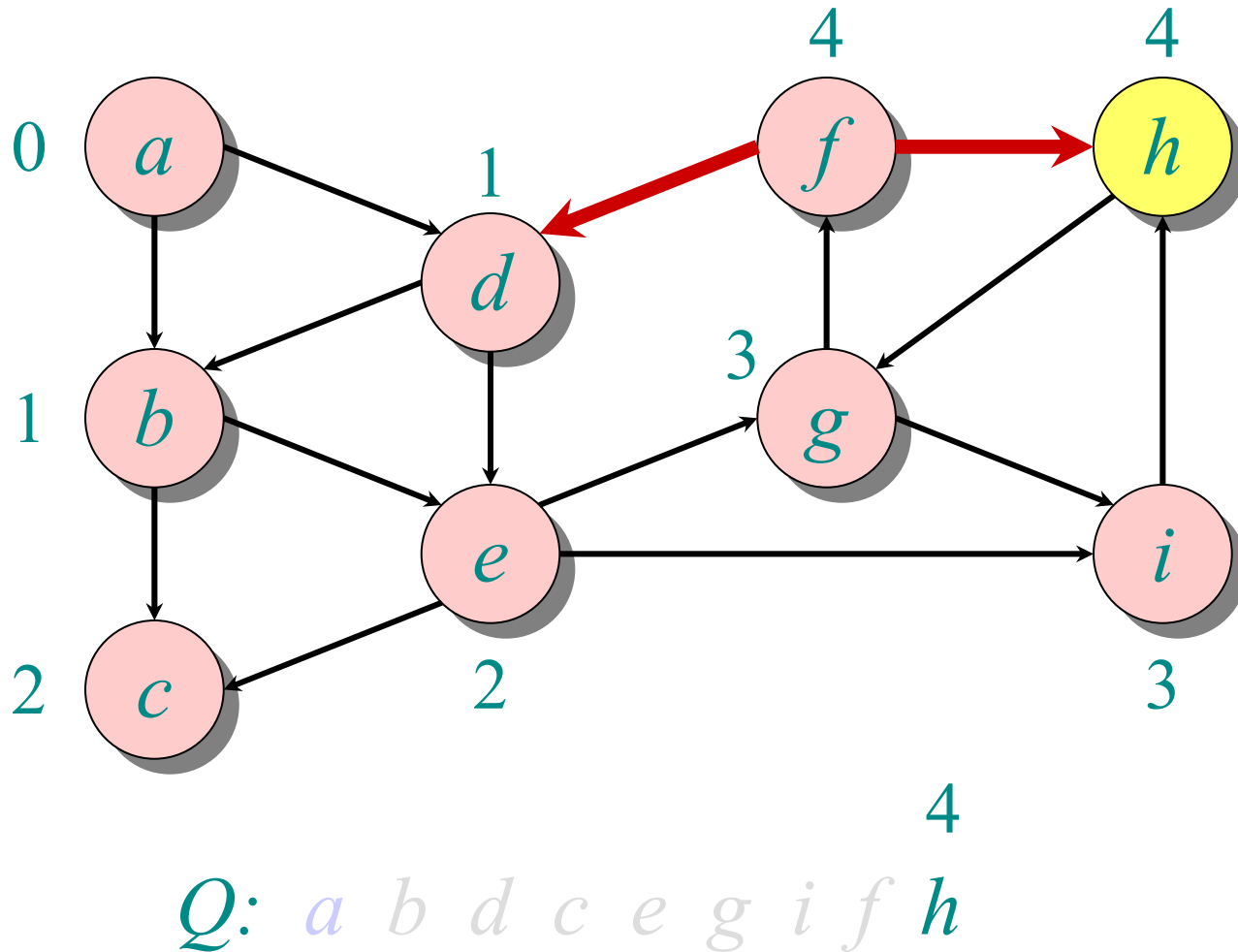

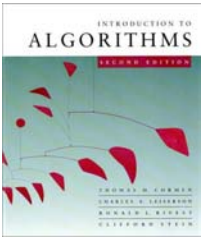

# Example of breadth-first search

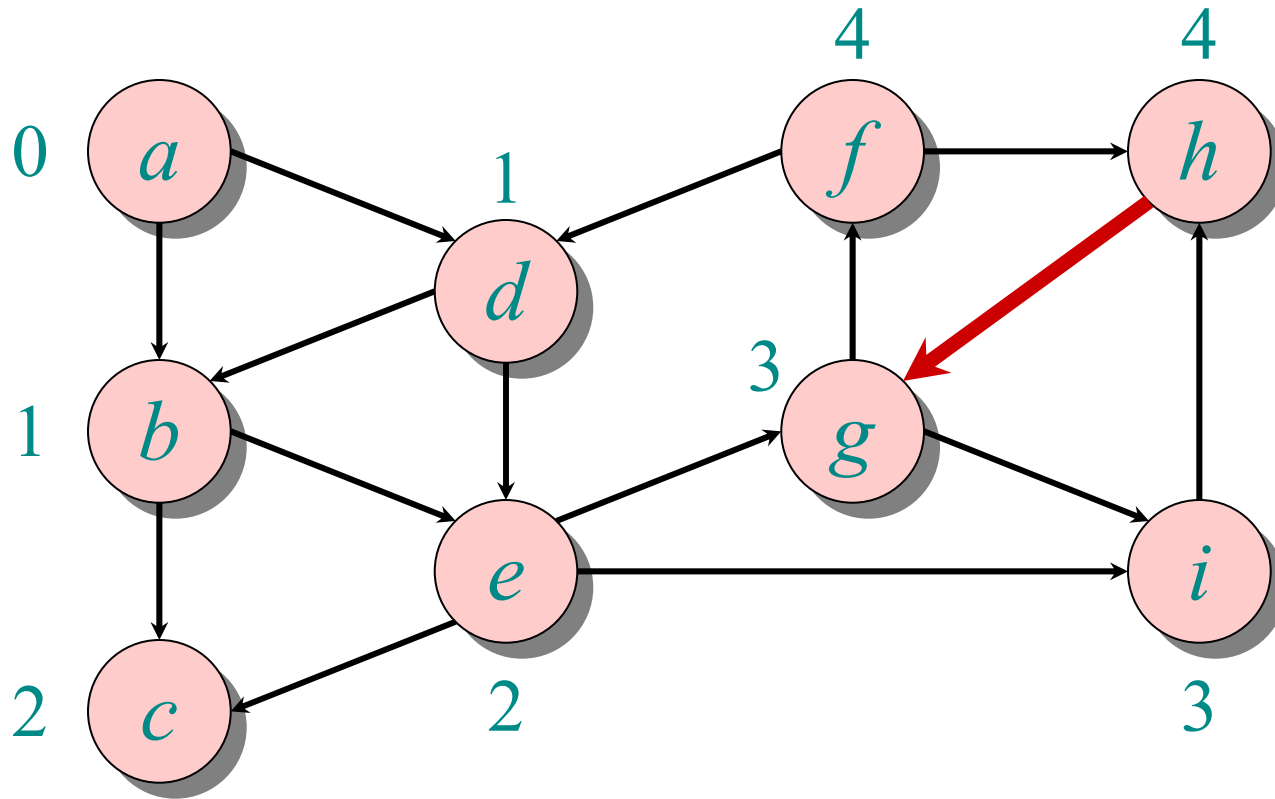

*Q*: *a b d c e g i f h*

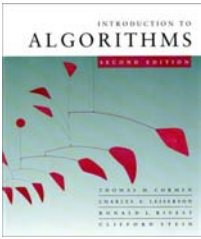

# Example of breadth-first search

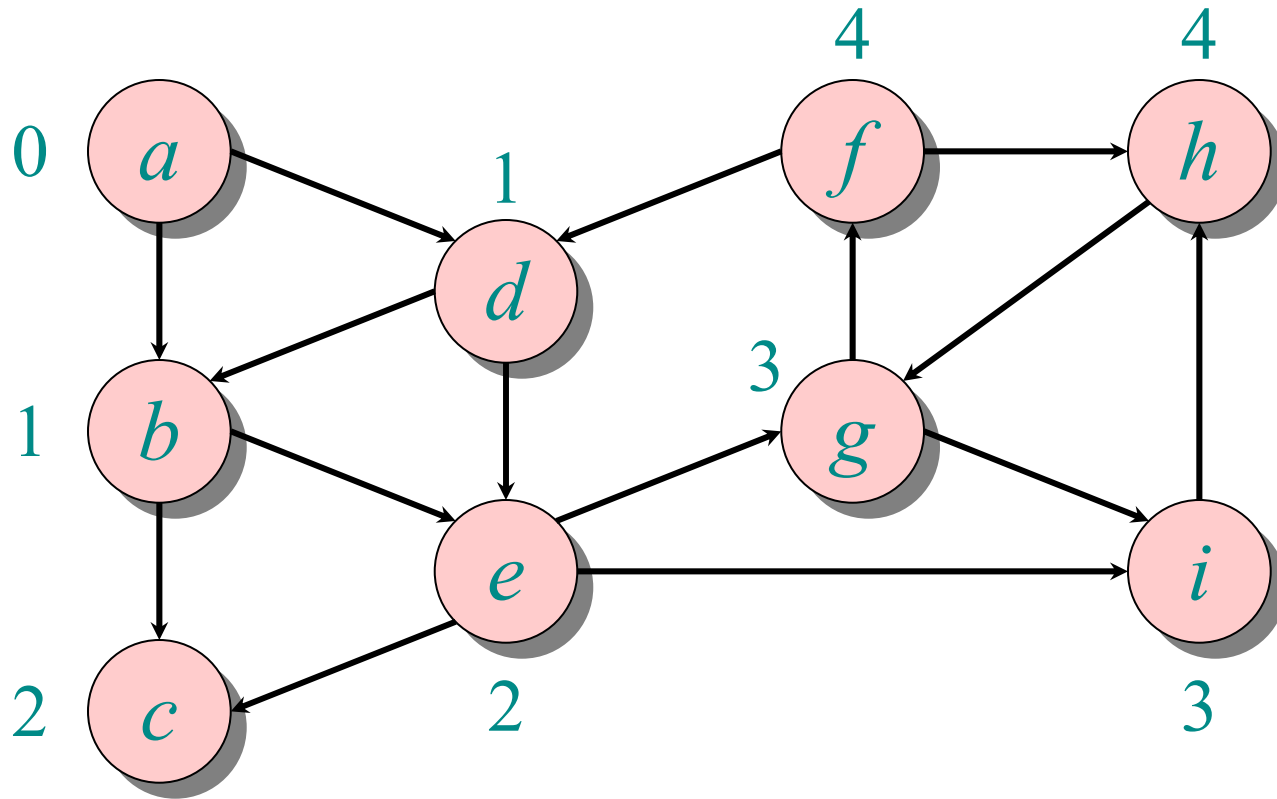

*Q: a b d c e g i f h*

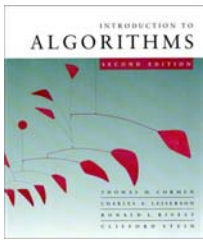

# Correctness of BFS

```
while  $Q \neq \emptyset$ 
do  $u \leftarrow \text{DEQUEUE}(Q)$ 
  for each  $v \in \text{Adj}[u]$ 
  do if  $d[v] = \infty$ 
    then  $d[v] \leftarrow d[u] + 1$ 
      ENQUEUE( $Q, v$ )
```

## Key idea:

The FIFO  $Q$  in breadth-first search mimics the priority queue  $Q$  in Dijkstra.

- **Invariant:**  $v$  comes after  $u$  in  $Q$  implies that  $d[v] = d[u]$  or  $d[v] = d[u] + 1$ .

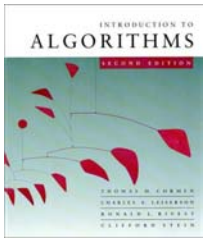

# How to find the actual shortest paths?

## Store a predecessor tree:

$d[s] \leftarrow 0$

**for** each  $v \in V - \{s\}$

**do**  $d[v] \leftarrow \infty$

$S \leftarrow \emptyset$

$Q \leftarrow V$        $\triangleright$   $Q$  is a priority queue maintaining  $V - S$

**while**  $Q \neq \emptyset$

**do**  $u \leftarrow \text{EXTRACT-MIN}(Q)$

$S \leftarrow S \cup \{u\}$

**for** each  $v \in \text{Adj}[u]$

**do if**  $d[v] > d[u] + w(u, v)$

**then**  $d[v] \leftarrow d[u] + w(u, v)$

$\pi[v] \leftarrow u$

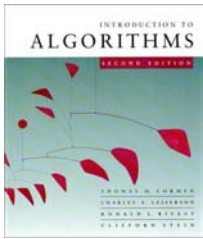

# Example of Dijkstra's algorithm

**Graph with nonnegative edge weights:**

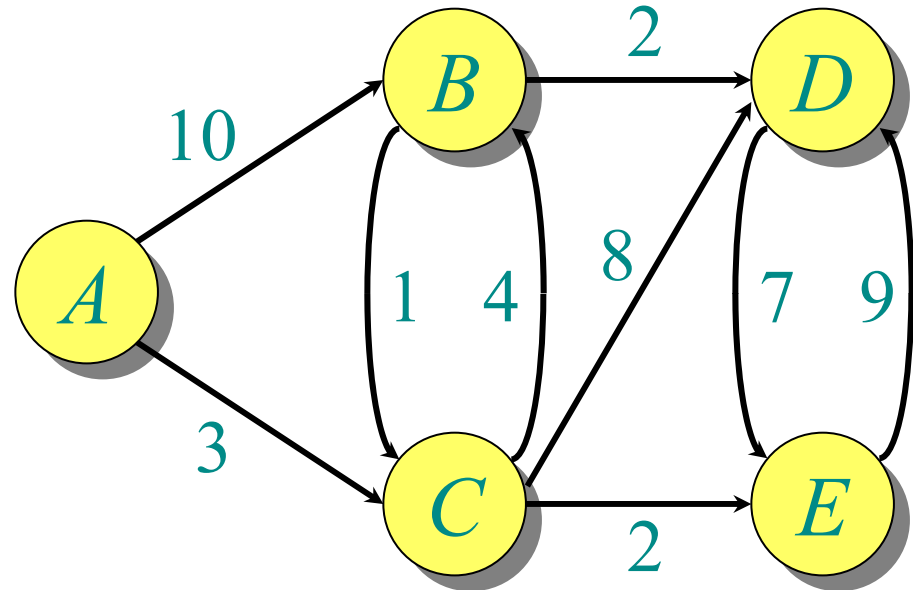

```
while  $Q \neq \emptyset$  do  
   $u \leftarrow \text{EXTRACT-MIN}(Q)$   
   $S \leftarrow S \cup \{u\}$   
  for each  $v \in \text{Adj}[u]$  do  
    if  $d[v] > d[u] + w(u, v)$  then  
       $d[v] \leftarrow d[u] + w(u, v)$   
       $\pi[v] \leftarrow u$ 
```

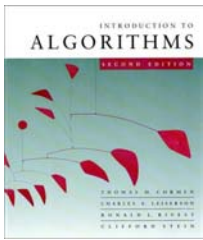

# Example of Dijkstra's algorithm

**Initialize:**

$S: \{\}$

$Q:$

<u>A</u>	<u>B</u>	<u>C</u>	<u>D</u>	<u>E</u>
0	$\infty$	$\infty$	$\infty$	$\infty$

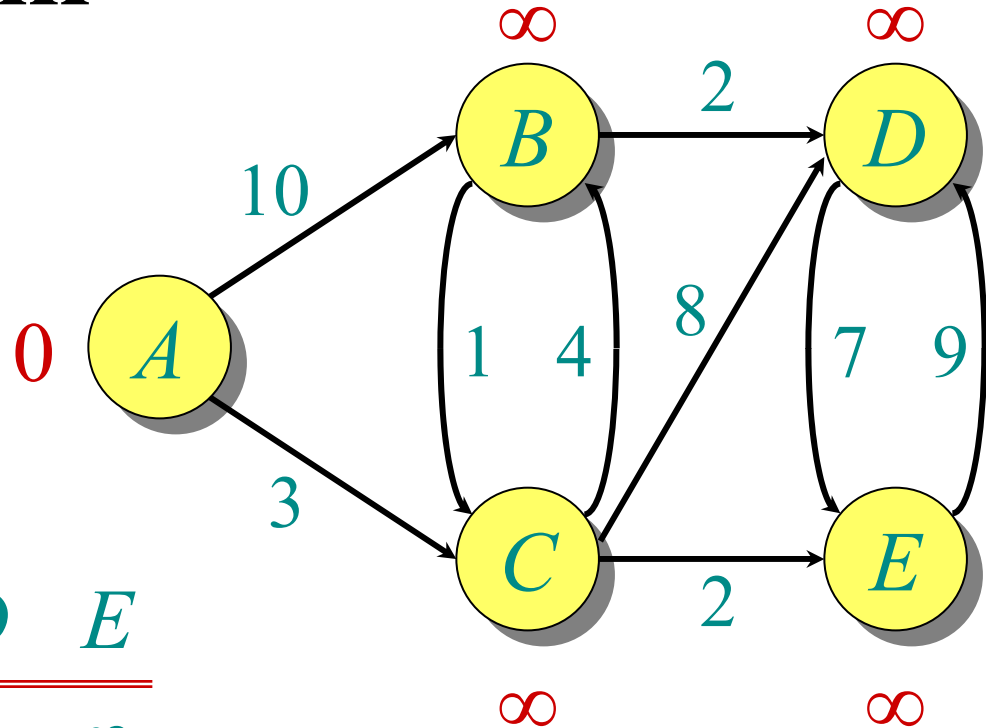

```
while  $Q \neq \emptyset$  do
   $u \leftarrow \text{EXTRACT-MIN}(Q)$ 
   $S \leftarrow S \cup \{u\}$ 
  for each  $v \in \text{Adj}[u]$  do
    if  $d[v] > d[u] + w(u, v)$  then
       $d[v] \leftarrow d[u] + w(u, v)$ 
       $\pi[v] \leftarrow u$ 
```

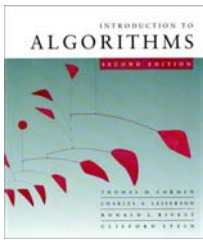

# Example of Dijkstra's algorithm

“A” ← **EXTRACT-MIN**(Q):

S: { A }

$\pi$ :     A    B    C    D    E

Q:     A    B    C    D    E

    0     $\infty$      $\infty$      $\infty$      $\infty$

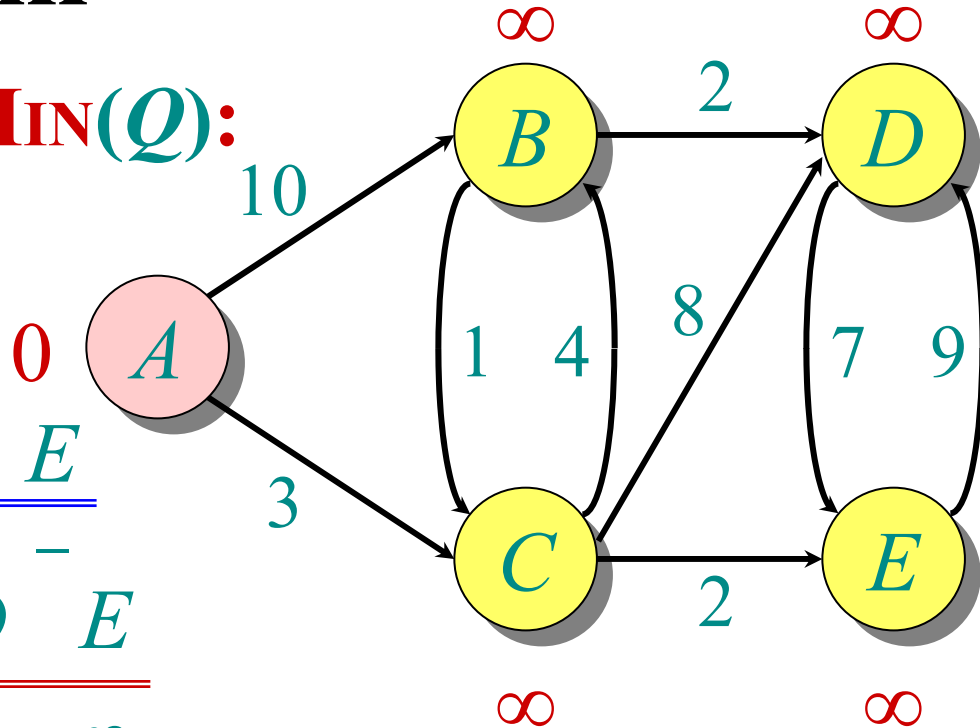

```

while Q ≠ ∅ do
  u ← EXTRACT-MIN(Q)
  S ← S ∪ {u}
  for each v ∈ Adj[u] do
    if d[v] > d[u] + w(u, v) then
      d[v] ← d[u] + w(u, v)
      π[v] ← u
  
```

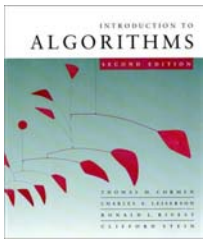

# Example of Dijkstra's algorithm

Relax all edges leaving  $A$ :

$S: \{A\}$

$\pi:$   $A$   $B$   $C$   $D$   $E$

$Q:$	$A$	$B$	$C$	$D$	$E$
	0	$\infty$	$\infty$	$\infty$	$\infty$
		10	3	-	-

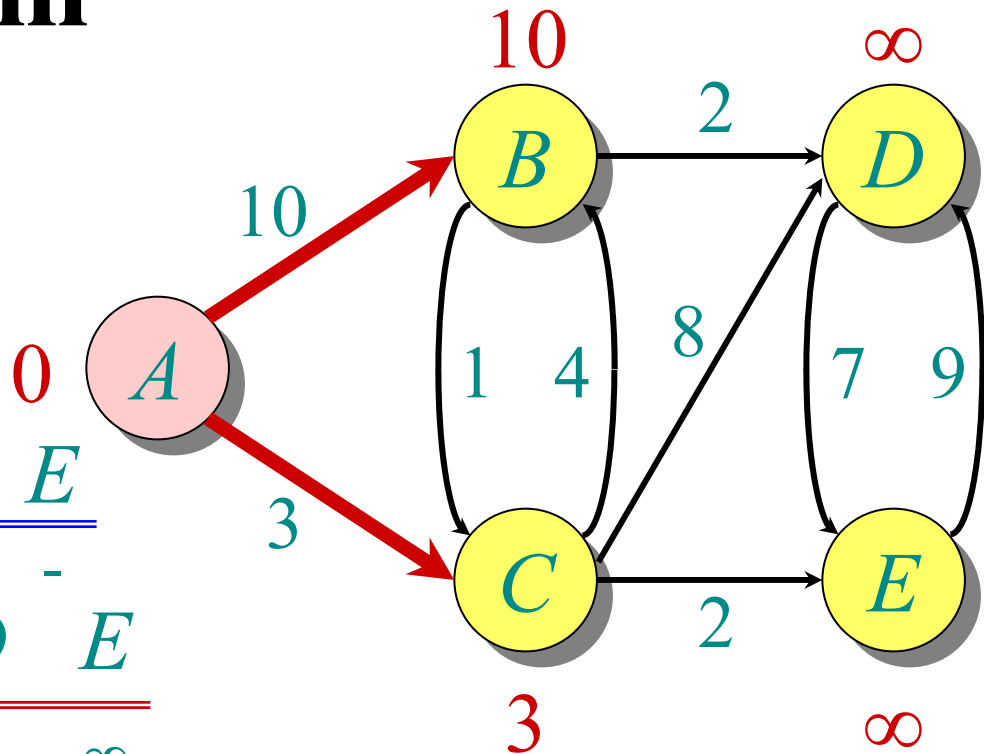

```

while  $Q \neq \emptyset$  do
   $u \leftarrow \text{EXTRACT-MIN}(Q)$ 
   $S \leftarrow S \cup \{u\}$ 
  for each  $v \in \text{Adj}[u]$  do
    if  $d[v] > d[u] + w(u, v)$  then
       $d[v] \leftarrow d[u] + w(u, v)$ 
       $\pi[v] \leftarrow u$ 
  
```

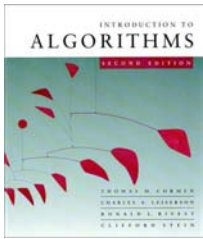

# Example of Dijkstra's algorithm

Relax all edges leaving  $A$ :

$S: \{A\}$

$\pi:$

$A$	$B$	$C$	$D$	$E$
-	$A$	$A$	-	-

$Q:$

$A$	$B$	$C$	$D$	$E$
0	$\infty$	$\infty$	$\infty$	$\infty$
	10	3	-	-

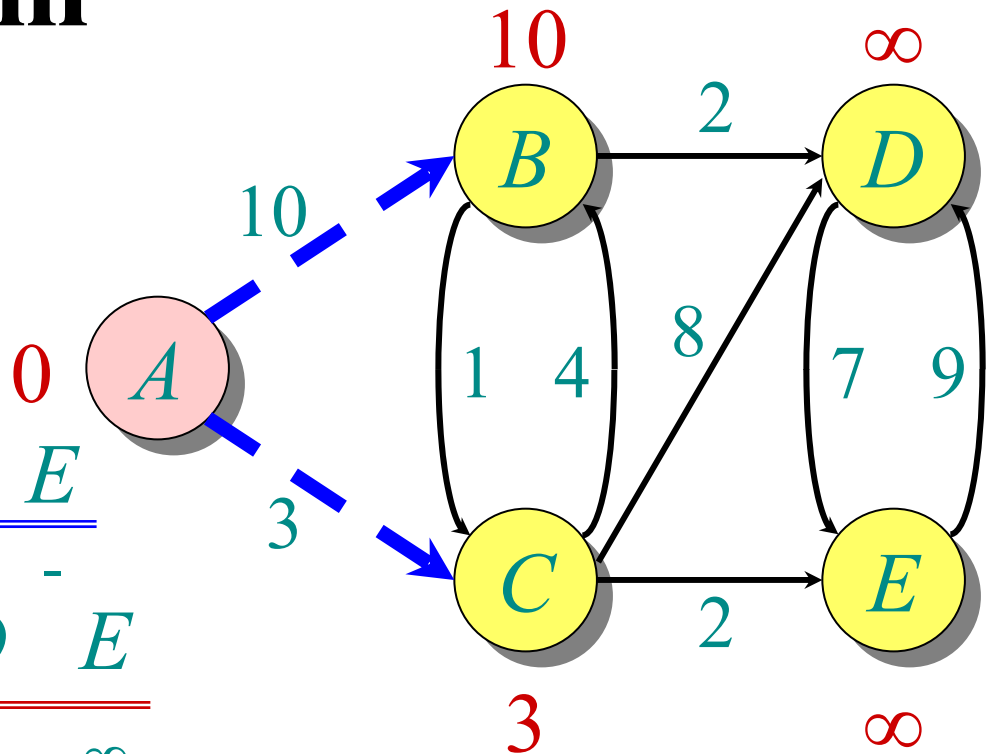

```

while  $Q \neq \emptyset$  do
   $u \leftarrow \text{EXTRACT-MIN}(Q)$ 
   $S \leftarrow S \cup \{u\}$ 
  for each  $v \in \text{Adj}[u]$  do
    if  $d[v] > d[u] + w(u, v)$  then
       $d[v] \leftarrow d[u] + w(u, v)$ 
       $\pi[v] \leftarrow u$ 
  
```

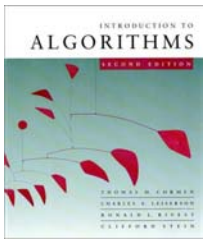

# Example of Dijkstra's algorithm

“C” ← EXTRACT-MIN(Q):

S: { A, C }

$\pi$ : A B C D E  
 - A A - -

Q:	A	B	C	D	E
	0	$\infty$	$\infty$	$\infty$	$\infty$
		10	3	-	-

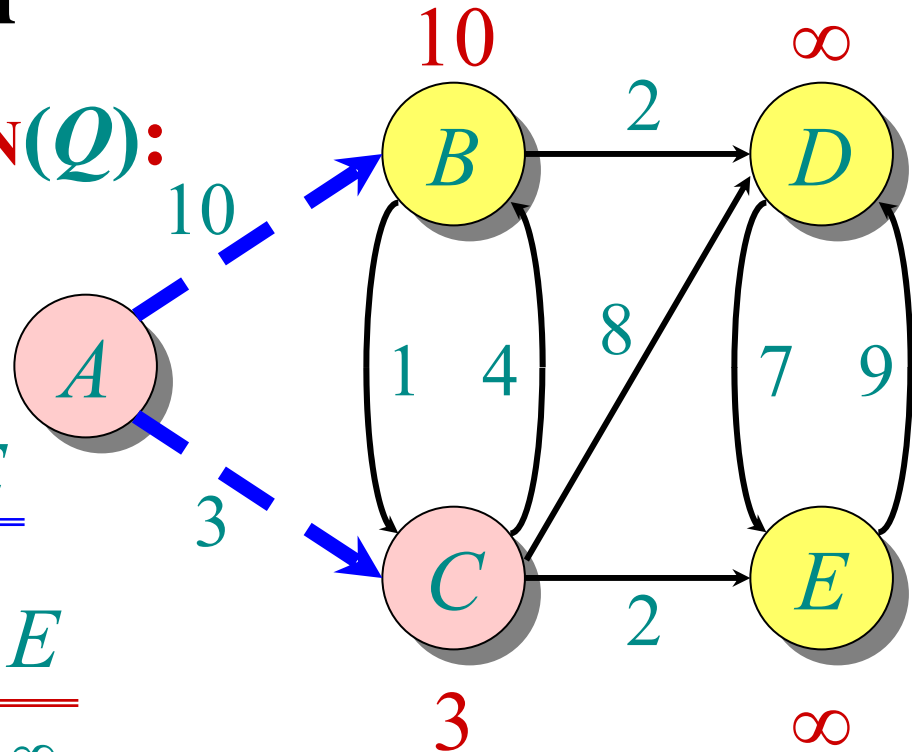

```

while Q ≠ ∅ do
  u ← EXTRACT-MIN(Q)
  S ← S ∪ {u}
  for each v ∈ Adj[u] do
    if d[v] > d[u] + w(u, v) then
      d[v] ← d[u] + w(u, v)
      π[v] ← u
  
```

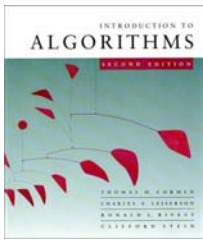

# Example of Dijkstra's algorithm

Relax all edges leaving  $C$ :

$S: \{A, C\}$

$\pi:$

$A$	$B$	$C$	$D$	$E$
-	A	A	-	-

$Q:$

$A$	$B$	$C$	$D$	$E$
0	$\infty$	$\infty$	$\infty$	$\infty$
	10	3	-	-
	7		11	5

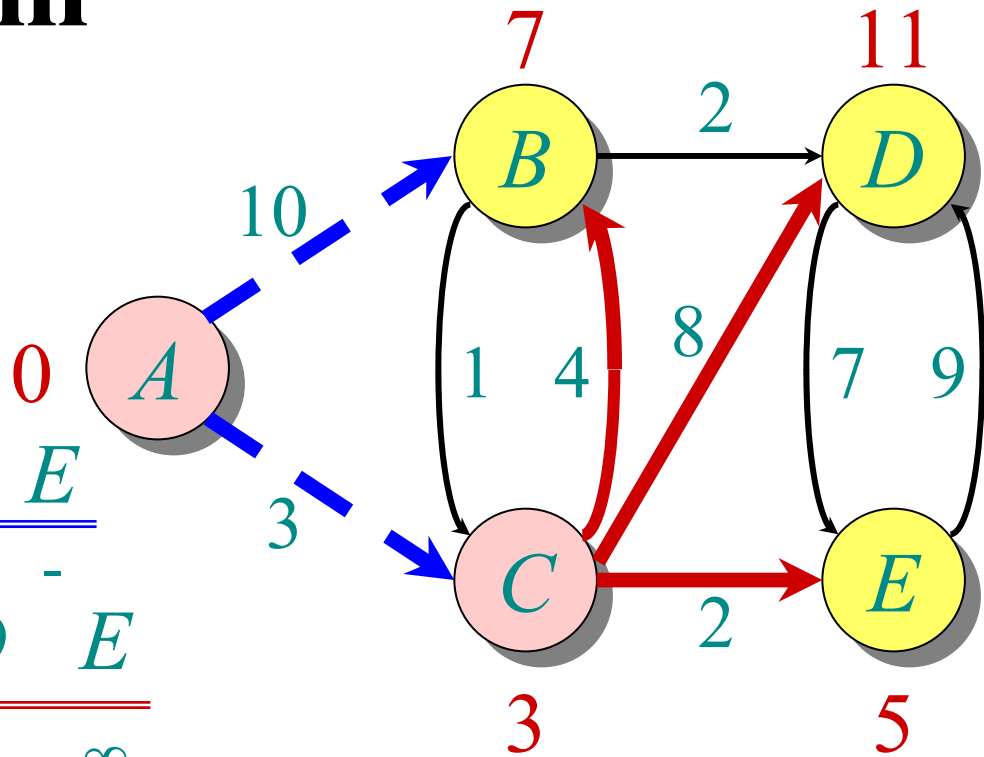

```

while  $Q \neq \emptyset$  do
   $u \leftarrow \text{EXTRACT-MIN}(Q)$ 
   $S \leftarrow S \cup \{u\}$ 
  for each  $v \in \text{Adj}[u]$  do
    if  $d[v] > d[u] + w(u, v)$  then
       $d[v] \leftarrow d[u] + w(u, v)$ 
       $\pi[v] \leftarrow u$ 
  
```

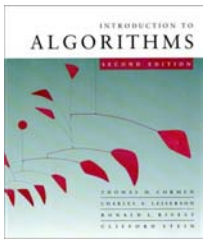

# Example of Dijkstra's algorithm

Relax all edges leaving  $C$ :

$S: \{A, C\}$

$\pi:$  A B C D E

- A A - -

$Q:$  A B C D E

0	$\infty$	$\infty$	$\infty$	$\infty$
	10	3	-	-
	7		11	5

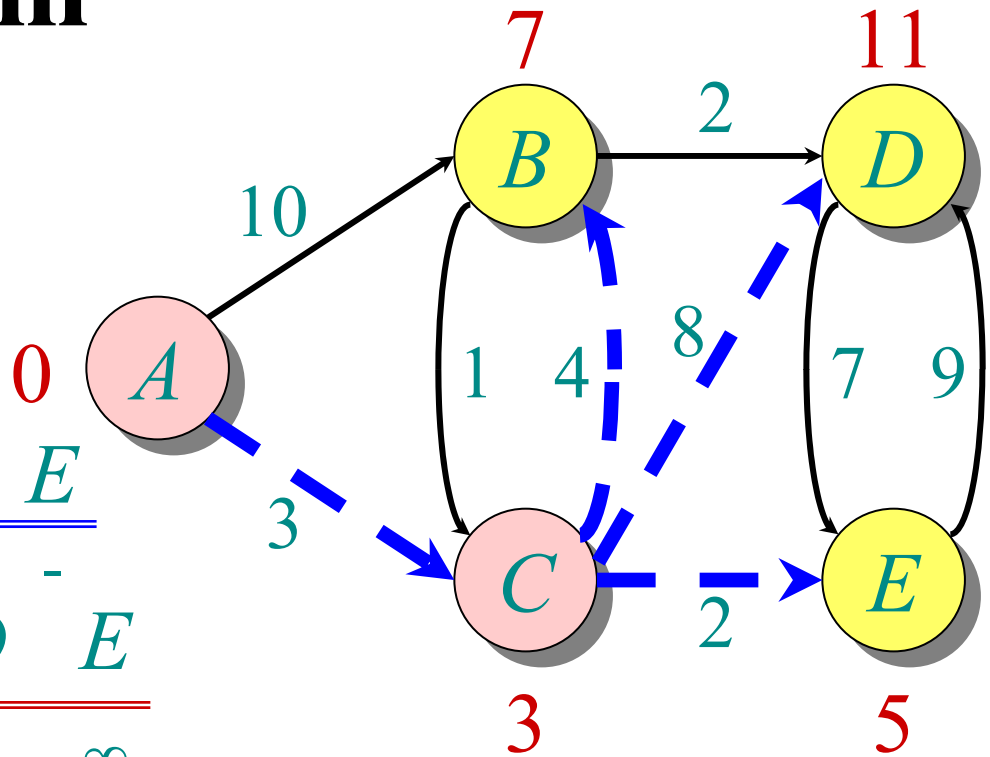

```

while  $Q \neq \emptyset$  do
   $u \leftarrow \text{EXTRACT-MIN}(Q)$ 
   $S \leftarrow S \cup \{u\}$ 
  for each  $v \in \text{Adj}[u]$  do
    if  $d[v] > d[u] + w(u, v)$  then
       $d[v] \leftarrow d[u] + w(u, v)$ 
       $\pi[v] \leftarrow u$ 
  
```

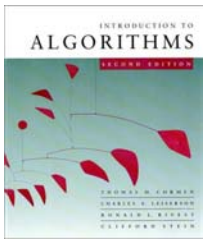

# Example of Dijkstra's algorithm

“E” ← **EXTRACT-MIN**(Q):

S: { A, C, E }      0

$\pi$ :     A    B    C    D    E  
       -    C    A    C    C

Q:	A	B	C	D	E
	0	$\infty$	$\infty$	$\infty$	$\infty$
		10	3	-	-
		7		11	5

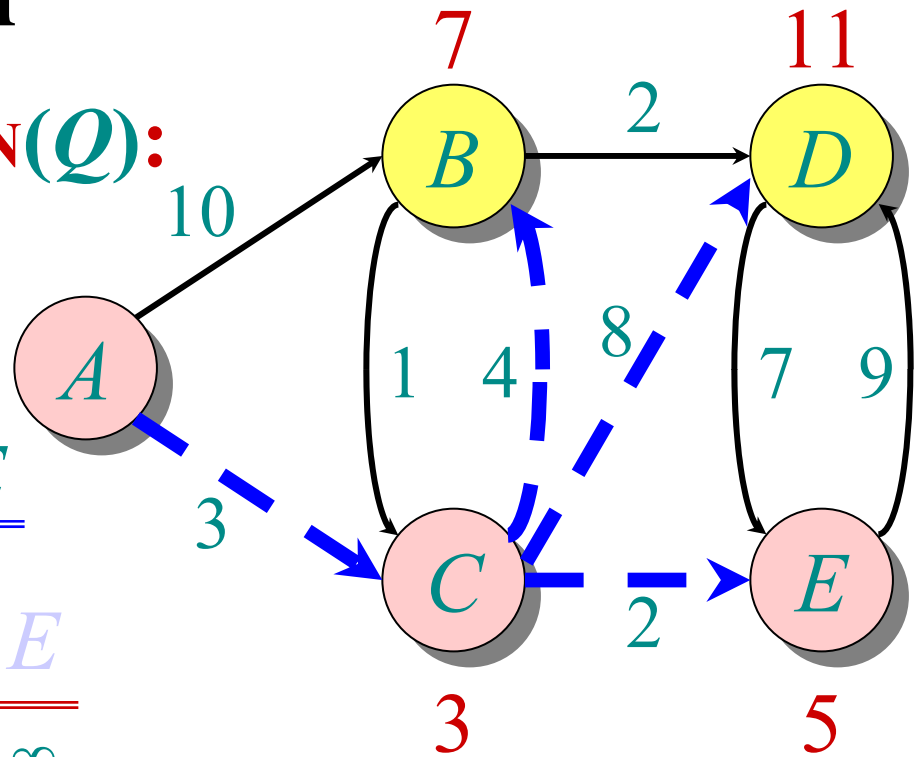

```

while Q ≠ ∅ do
  u ← EXTRACT-MIN(Q)
  S ← S ∪ {u}
  for each v ∈ Adj[u] do
    if d[v] > d[u] + w(u, v) then
      d[v] ← d[u] + w(u, v)
      π[v] ← u
  
```

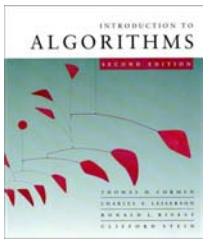

# Example of Dijkstra's algorithm

Relax all edges leaving  $E$ :

$S: \{A, C, E\}$

$\pi:$

$A$	$B$	$C$	$D$	$E$
-	$C$	$A$	$C$	$C$

$Q:$

$A$	$B$	$C$	$D$	$E$
0	$\infty$	$\infty$	$\infty$	$\infty$
10	3	$\infty$	$\infty$	$\infty$
7		11	5	
7		11		

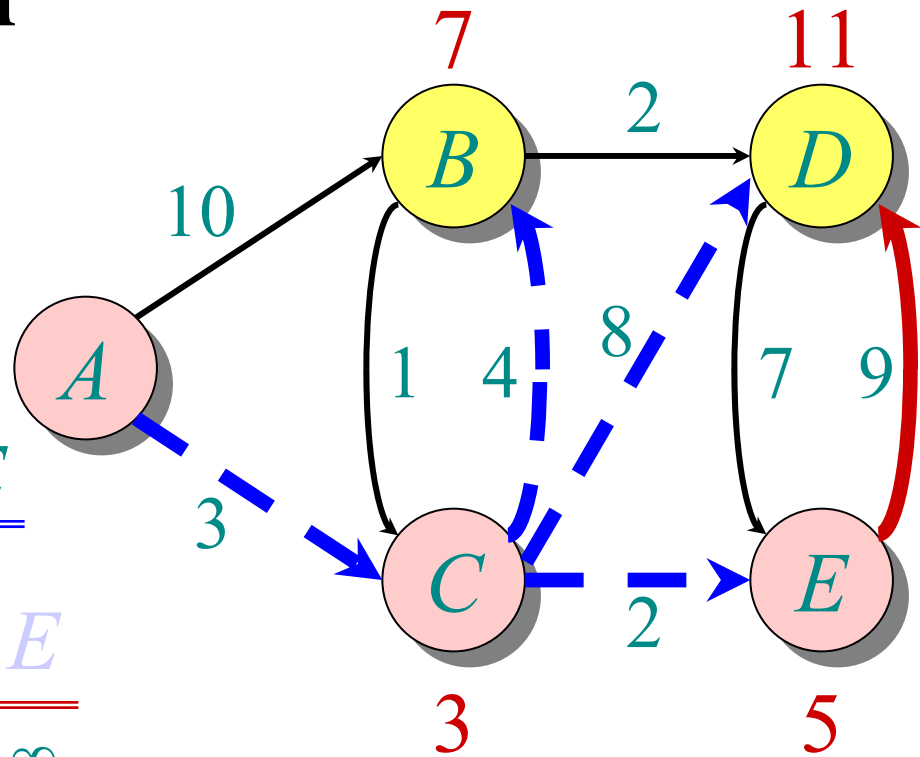

```

while  $Q \neq \emptyset$  do
   $u \leftarrow \text{EXTRACT-MIN}(Q)$ 
   $S \leftarrow S \cup \{u\}$ 
  for each  $v \in \text{Adj}[u]$  do
    if  $d[v] > d[u] + w(u, v)$  then
       $d[v] \leftarrow d[u] + w(u, v)$ 
       $\pi[v] \leftarrow u$ 
  
```

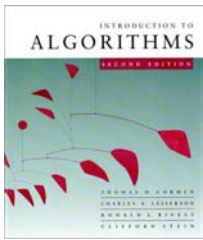

# Example of Dijkstra's algorithm

“B” ← **EXTRACT-MIN**(Q):

S: { A, C, E, B }    0

$\pi$ :     A    B    C    D    E  
       -    C    A    C    C

Q:	A	B	C	D	E
	0	$\infty$	$\infty$	$\infty$	$\infty$
	10	3	$\infty$	$\infty$	
	7		11	5	
	7		11		

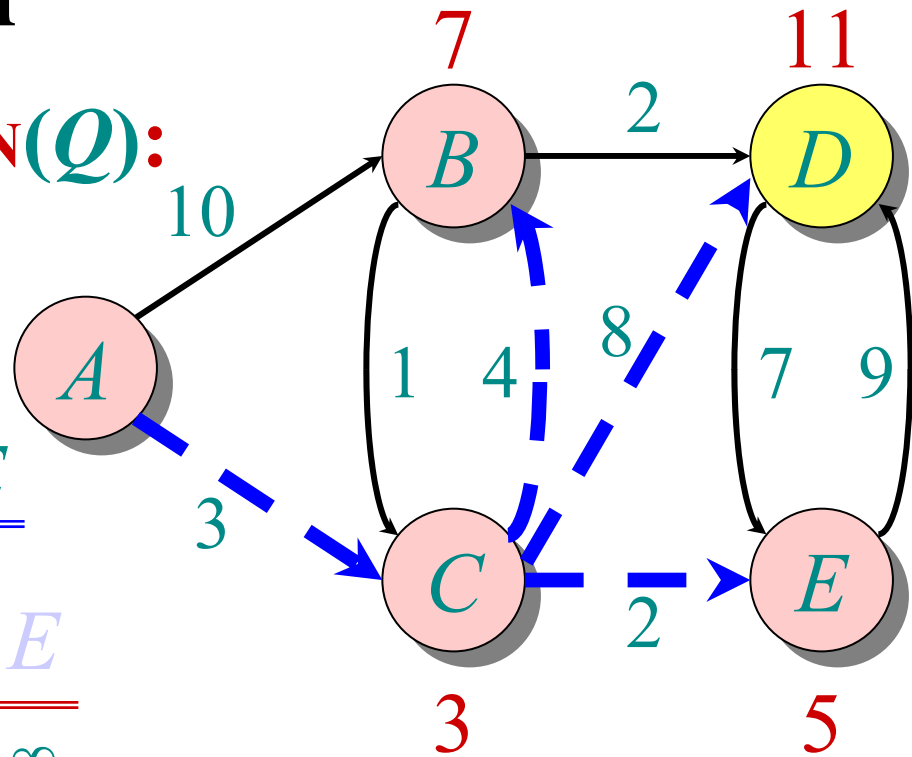

```

while Q ≠ ∅ do
  u ← EXTRACT-MIN(Q)
  S ← S ∪ {u}
  for each v ∈ Adj[u] do
    if d[v] > d[u] + w(u, v) then
      d[v] ← d[u] + w(u, v)
      π[v] ← u
  
```

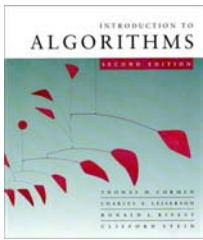

# Example of Dijkstra's algorithm

Relax all edges leaving  $B$ :

$S: \{A, C, E, B\}$     0

$\pi:$        
      
 -    C    A    B    C

$Q:$	$A$	$B$	$C$	$D$	$E$
	0	$\infty$	$\infty$	$\infty$	$\infty$
	10	3	$\infty$	$\infty$	$\infty$
	7		11	5	
	7		11		
			9		

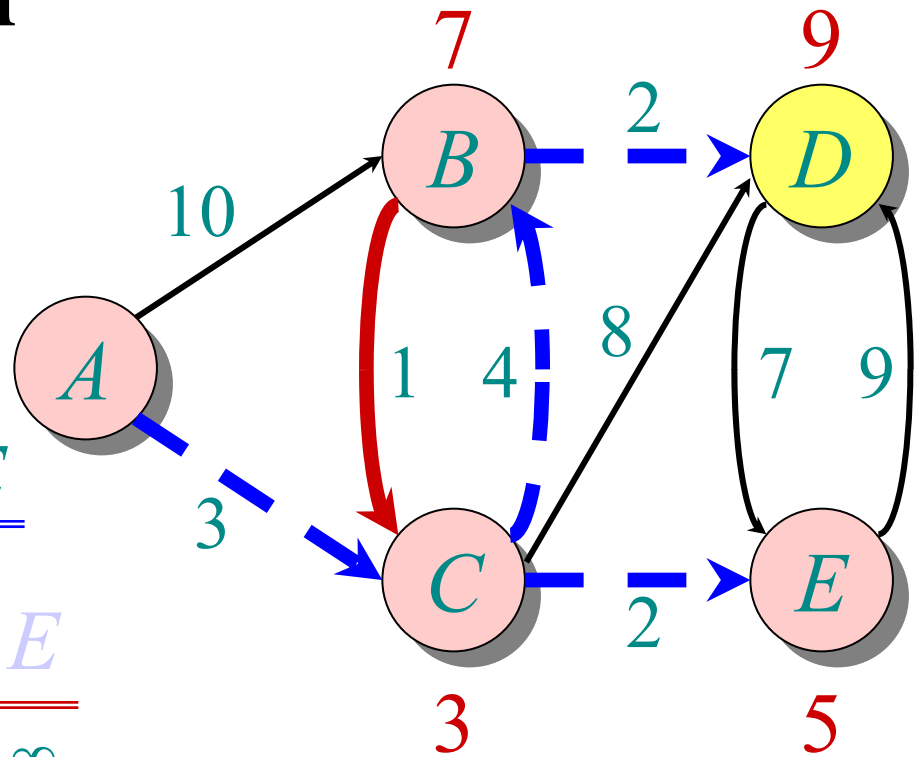

```

while  $Q \neq \emptyset$  do
   $u \leftarrow \text{EXTRACT-MIN}(Q)$ 
   $S \leftarrow S \cup \{u\}$ 
  for each  $v \in \text{Adj}[u]$  do
    if  $d[v] > d[u] + w(u, v)$  then
       $d[v] \leftarrow d[u] + w(u, v)$ 
       $\pi[v] \leftarrow u$ 
  
```

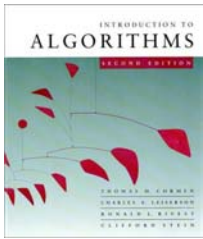

# Example of Dijkstra's algorithm

“D” ← **EXTRACT-MIN**(Q):

S: { A, C, E, B, D } 0

$\pi$ :     A    B    C    D    E  
       -    C    A    C    C

Q:	A	B	C	D	E
	0	$\infty$	$\infty$	$\infty$	$\infty$
		10	3	$\infty$	$\infty$
		7		11	5
		7		11	
				9	

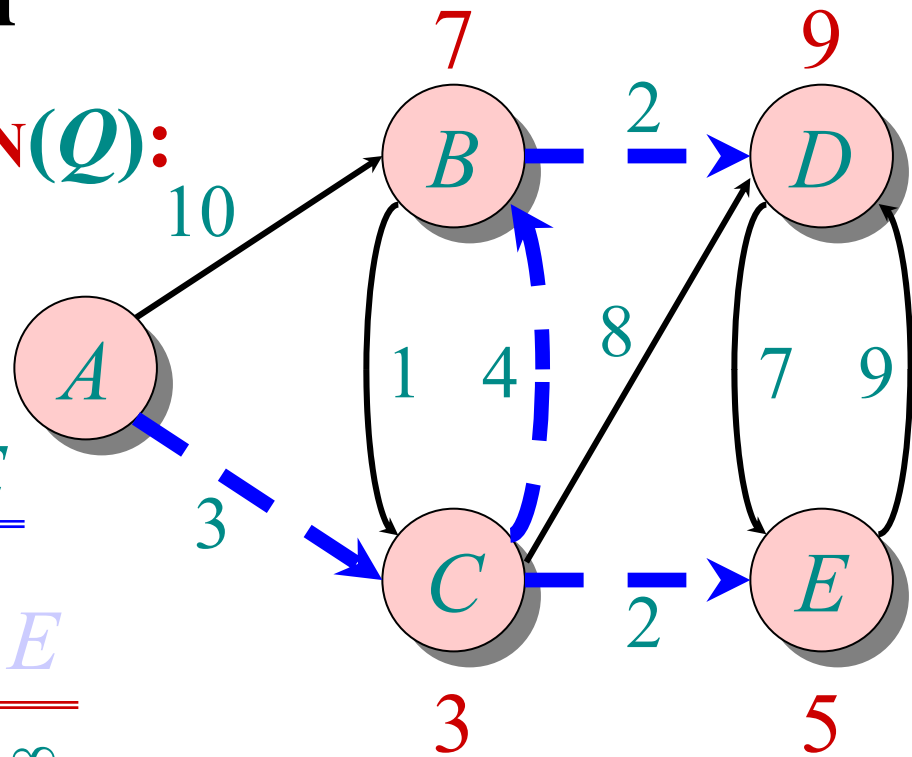

```

while Q ≠ ∅ do
  u ← EXTRACT-MIN(Q)
  S ← S ∪ {u}
  for each v ∈ Adj[u] do
    if d[v] > d[u] + w(u, v) then
      d[v] ← d[u] + w(u, v)
      π[v] ← u
  
```